

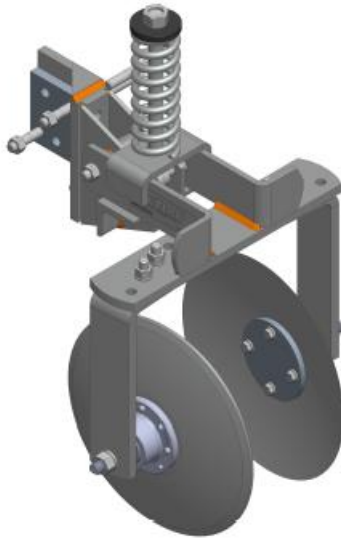

2920-012 DISC SEALER 12" SMOOTH  
2920-016 DISC SEALER 16" SMOOTH  
2920-016-N DISC SEALER 16" NOTCHED

OPERATOR'S MANUAL  
PARTS IDENTIFICATION  
2565-412\_REV\_H • 02/2023



**YETTER MANUFACTURING CO.**  
*FOUNDED 1930*

Colchester, IL 62326-0358  
Toll free: 800/447-5777  
309/776-3222 (Fax)  
Website: [www.yetterco.com](http://www.yetterco.com)  
E-mail: [info@yetterco.com](mailto:info@yetterco.com)

**YETTER**

## FOREWORD

You've just joined an exclusive but rapidly growing club.

For our part, we want to welcome you to the group and thank you for buying a Yetter product.

We hope your new Yetter products will help you achieve both goals-increase your productivity and increase your efficiency so that you may generate more profit.

This operator's manual has been designed into four major sections: Foreword, Safety Precautions, Installation Instructions and Parts Breakdown.



This **SAFETY ALERT SYMBOL** indicates important safety messages in the manual. When you see this symbol, be alert to the possibility of **PERSONAL INJURY** and carefully read the message that follows.

The word **NOTE** is used to convey information that is out of context with the manual text. It contains special information such as specifications, techniques and reference information of a supplementary nature.

The word **IMPORTANT** is used in the text when immediate damage will occur to the machine due

to improper technique or operation. Important will apply to the same information as specified by note only of an immediate and urgent nature.

It is the responsibility of the user to read the operator's manual and comply with the safe and correct operating procedure and to lubricate and maintain the product according to the maintenance schedule in the operator's manual.

The user is responsible for inspecting his machine and for having parts repaired or replaced when continued use of the product would cause damage or excessive wear to the other parts.

It is the user's responsibility to deliver his machine to the Yetter dealer who sold him the product for service or replacement of defective parts, which are covered by the warranty policy.

If you are unable to understand or follow the instructions provided in this publication, consult your local Yetter dealer or contact:

### YETTER MANUFACTURING CO.

309/776-4111

800/447-5777

309/776-3222 (FAX)

Website: [www.yetterco.com](http://www.yetterco.com)

E-mail: [info@yetterco.com](mailto:info@yetterco.com)

## WARRANTY

Yetter Manufacturing warrants all products manufactured and sold by it against defects in material. This warranty being expressly limited to replacement at the factory of such parts or products as shall appear to be defective after inspection. This warranty does not obligate the Company to bear cost of labor in replacement of parts. It is the policy of the Company to make improvements without incurring obligations to add them to any unit already sold. No warranty is made or authorized to be made, other than herein set forth. This warranty is in effect for one year after purchase.

DEALER: \_\_\_\_\_

**Yetter Manufacturing warrants its own products only and cannot be responsible for damages to equipment on which mounted.**

## SAFETY PRECAUTIONS

You can make your farm a safer place to live and work if you observe the safety precautions given. Study these precautions carefully and insist those working with you and for you follow the precautions.

Finally, remember this an accident is usually caused by someone's carelessness, neglect or oversight.

**A brief description of signal words that may be used in this manual:**

**CAUTION:** Used as a general reminder of good safety practices or to direct attention to unsafe practices.

**WARNING:** Denotes a specific potential hazard.

**DANGER:** Denotes the most serious specific potential hazard.



### CAUTION

Consult your implement and tractor operator's manual for correct and safe operating practices. Be aware of towed implement width and allow safe clearance.



### CAUTION: SAFETY SIGNS

Safety decals are placed on the implement to alert the operator and others to the risk of personal injury or unsafe operation during normal operations and servicing.

1. The safety decals must be kept clean and in good condition to ensure that they are legible.
2. Safety decals must be replaced if they are missing or illegible.
3. When components are replaced during repair or servicing, check that the new components include the necessary safety signs.
4. Replacement safety decals may be obtained from your local dealer.



### WARNING

Read these instructions carefully to acquaint yourself with the attachments. Working with unfamiliar equipment can lead to accidents.

Never clean, lubricate or adjust a machine that is in motion.

If machine must be serviced in the raised position, jack or block it up to prevent it from accidentally falling and injuring someone.

Do not allow children to operate this equipment.

Use speeds and caution dictated by the terrain being traversed. Do not operate on any slope steep enough to cause tipping or loss of control.

Be sure all personnel are clear of the immediate area before operating.

Read and understand the operator's manual and require all other persons who will operate the equipment to do the same.

If operating on public roadways, where legal, be certain all lighting is operating properly and observe all traffic laws.

Attach a slow moving vehicle emblem to the rear of the trailing implement.

Beware of increased stopping distances and control effort when operating with implements attached.

Be familiar with all controls and be prepared to stop engine and equipment quickly in an emergency.

**FAILURE TO HEED MAY RESULT IN PERSONAL INJURY OR DEATH.**

# BOLT TORQUE

## Mounting bolts and hardware

Before operating the Disc Sealer for the first time, check to be sure that all hardware is tight. Check all hardware again after approximately 50 hours of operation and at the beginning of each season.

All hardware used on the Disc Sealer is Grade 5 unless otherwise noted. Grade 5 cap screws are marked with three radial lines on the head. If hardware must be replaced, be sure to replace it with hardware of equal size, strength and thread type. Refer to the torque values chart when tightening hardware.





**Important:** Over tightening hardware can cause as much damage as when under tightening. Tightening hardware beyond the recommended range can reduce its shock load capacity.

The chart below is a guide for proper torque. Use it unless a specified torque is called out elsewhere in the manual.

Torque is the force you apply to the wrench handle or the cheater bar, times the length of the handle or bar. Use a torque wrench whenever possible.

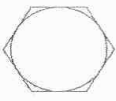
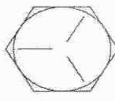
The following table shows torque in ft. lbs. for coarse thread hardware.

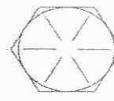
BOLT DIA. AND THREADS PER INCH	 GRADE 2	 OR  GRADE 5 A-325	 GRADE 8
1/4	6	10	14
5/16	12	20	30
3/8 - 16	25	35	50
7/16 - 14	35	55	80
1/2 - 13	55	85	125
9/16 - 12	75	125	175
5/8 - 11	105	170	235
3/4 - 10	185	305	425
7/8 - 9	170	445	690
1-8	260	670	1030
1 1/8 - 7	365	900	1460
1 1/4 - 7	515	1275	2060
1 3/8 - 6	675	1675	2700
1 1/2 - 6	900	2150	3500
1 3/4 - 5	1410	3500	5600

Lubricate all bearings and moving parts as assembled and make certain that they work freely.



**WARNING:** Never work around the toolbar/implement while in a raised position without using safety lockups.



**CAUTION:** The Disc Sealer attachments are very heavy. Pay extra attention to lifting techniques while handling and or maneuvering the opener during assembly. Failure to do so may lead to personal injury.

# ASSEMBLY

“Barn Yard Setting” – set the sealer blade to 2” closer to the bottom of the knife than the depth that the knife will be used at. Example: knife at 6” depth, set the blades to 4” above the bottom of the knife. Adjust the blade pitch as needed to cover the knife track with soil. Tighten all hardware to the recommended amount of torque unless otherwise stated.

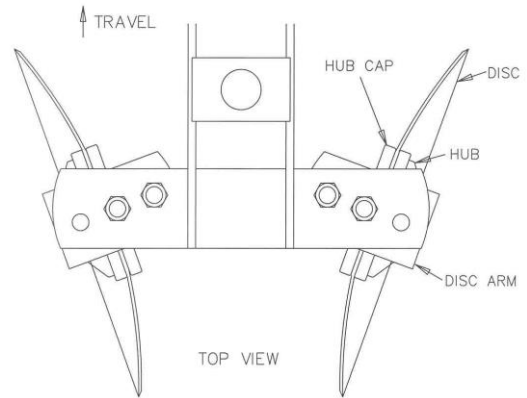
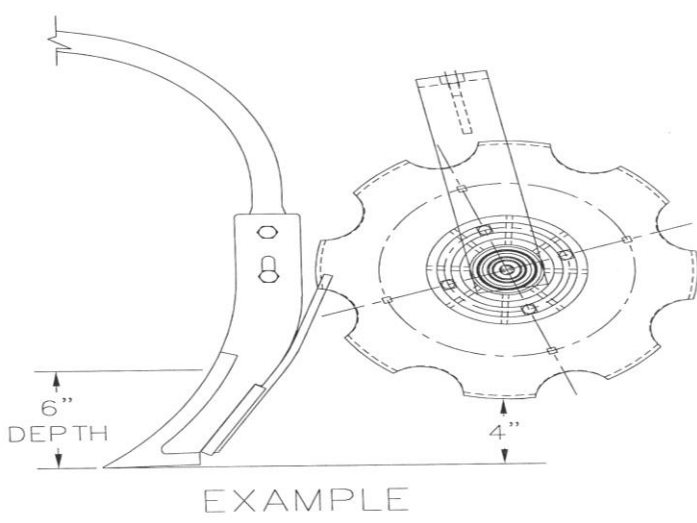

S196-1

## MAINTENANCE

### Lubrication Symbols



Lubricate with grease at hourly interval indicated on symbol.

### Lubrication Intervals

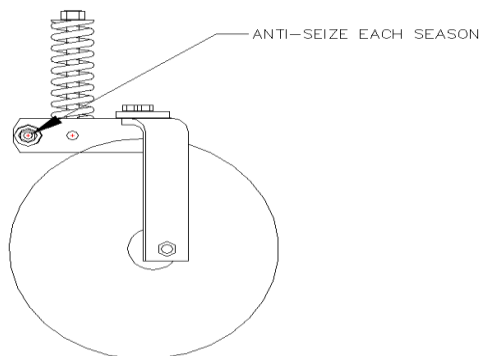

S422-8-LUBRICATION

**IMPORTANT: The recommended service intervals are based on normal conditions; severe or unusual conditions may require more frequent lubrication.**

**PARTS IDENTIFICATION**  
**2920-012A DISC SEALER**  
 MANUFACTURED 06-01-2021 TO PRESENT

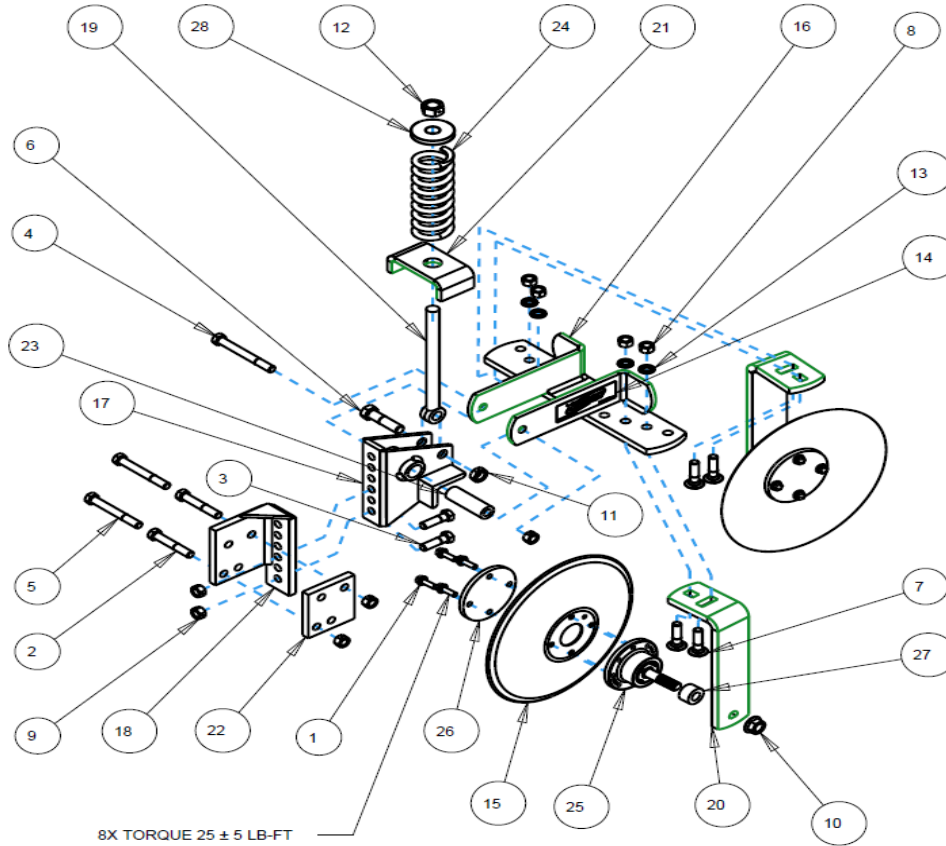

ITEM	PART NO	DESCRIPTION	QTY
1	2502-221	5/16-18 X 1 HHFS GRADE 5	8
2	2502-313	1/2-13 X 3 HHCS GRADE 5	2
3	2502-317	1/2-13 X 1-3/4 HHCS GRADE 5	2
4	2502-363	1/2-13 X 4-1/2 HHCS GRADE 5	1
5	2502-364	1/2-13 X 4 HHCS GRADE 5	2
6	2502-393	5/8-11 X 2-1/2 HHCS GRADE 5	1
7	2505-345	1/2-13 X 2 CARRIAGE BOLT GRADE 5	4
8	2520-352	1/2-13 HEX NUT GRADE 2	4
9	2520-357	1/2-13 LOCK HEX NUT GRADE A	5
10	2520-465	5/8-11 FLANGE NUT GRADE 8	2
11	2520-467	5/8-11 JAM LOCKNUT	1
12	2520-515	3/4-10 HEX LOCK NUT GRADE A	1
13	2525-352	1/2 LOCKWASHER	4
14	2565-162	YETTER DECAL	2
15	2571-181	SMOOTH DISC 12"	2
16	2920-209	PIVOT ARM	1
17	2920-210	MOUNTING BRACKET	1
18	2920-211	SHANK MOUNT BRACKET	1
19	2920-324	3/4" EYEBOLT WITH 5/8" EYE	1
20	2920-329	ARM	2
21	2920-330	SPRING BRACKET	1
22	2920-339	CLAMP PLATE SHANK MOUNT	1
23	2920-342	INNER PIVOT BUSHING	1
24	2920-350	SPRING	1
25	2965-501	HUB ASSEMBLY 2.406 SPINDLE	2
26	2965-503	HUB CAP	2
27	2967-302	SPACER 3/4"	2
28	2975-302	SPRING BUSHING	1

# PARTS IDENTIFICATION

## 2920-016A DISC SEALER

MANUFACTURED 06-01-2021 TO PRESENT

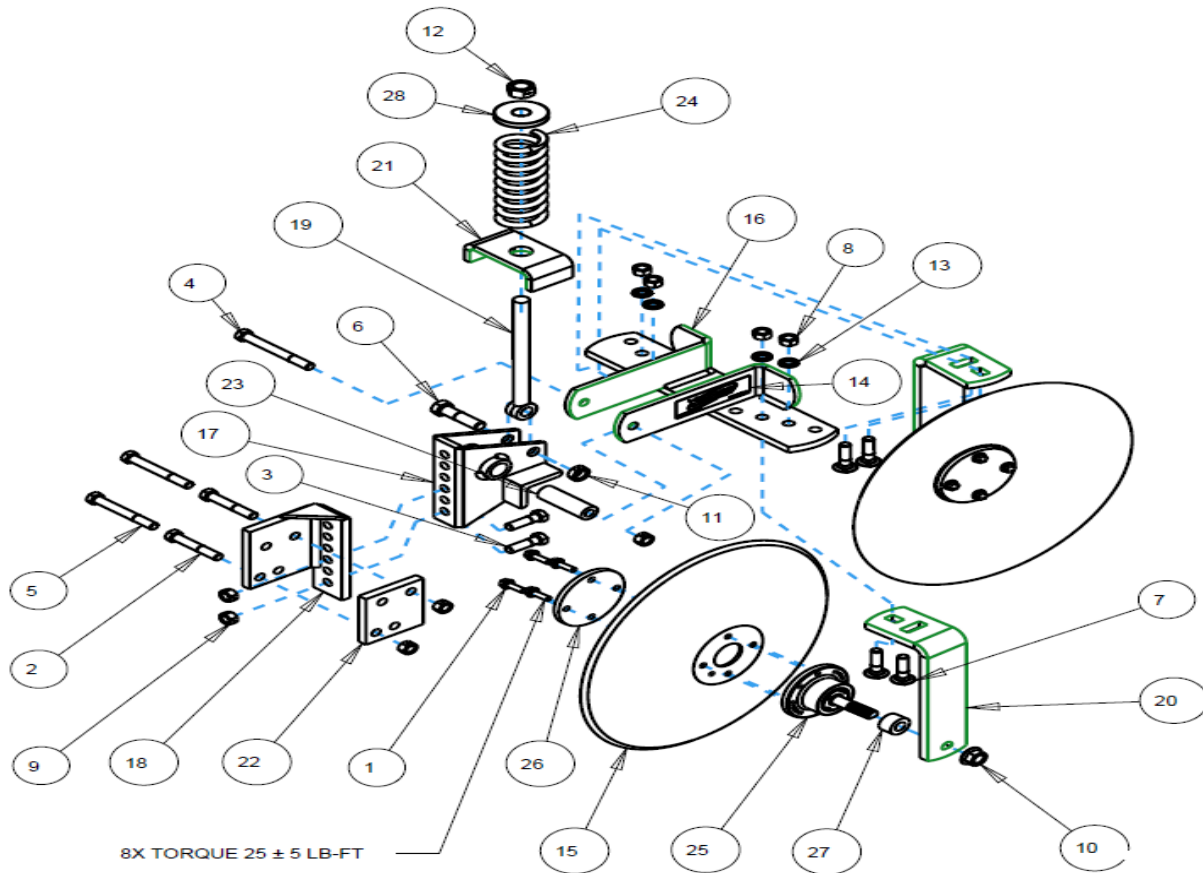

ITEM	PART NO	DESCRIPTION	QTY
1	2502-221	5/16-18 X 1 HHFS GRADE 5	8
2	2502-313	1/2-13 X 3 HHCS GRADE 5	2
3	2502-317	1/2-13 X 1-3/4 HHCS GRADE 5	2
4	2502-363	1/2-13 X 4-1/2 HHCS GRADE 5	1
5	2502-364	1/2-13 X 4 HHCS GRADE 5	2
6	2502-393	5/8-11 X 2-1/2 HHCS GRADE 5	1
7	2505-345	1/2-13 X 2 CARRIAGE BOLT GRADE 5	4
8	2520-352	1/2-13 HEX NUT GRADE 2	4
9	2520-357	1/2-13 LOCK HEX NUT GRADE A	5
10	2520-465	5/8-11 FLANGE NUT GRADE 8	2
11	2520-467	5/8-11 JAM LOCKNUT	1
12	2520-515	3/4-10 HEX LOCK NUT GRADE A	1
13	2525-352	1/2 LOCKWASHER	4
14	2565-162	YETTER DECAL	2
15	2571-173	SMOOTH DISC 16"	2
16	2920-209	PIVOT ARM	1
17	2920-210	MOUNTING BRACKET	1
18	2920-211	SHANK MOUNT BRACKET	1
19	2920-324	3/4" EYEBOLT WITH 5/8" EYE	1
20	2920-329	ARM	2
21	2920-330	SPRING BRACKET	1
22	2920-339	CLAMP PLATE SHANK MOUNT	1
23	2920-342	INNER PIVOT BUSHING	1
24	2920-350	SPRING	1
25	2965-501	HUB ASSEMBLY 2.406 SPINDLE	2
26	2965-503	HUB CAP	2
27	2967-302	SPACER 3/4"	2
28	2975-302	SPRING BUSHING	1

# PARTS IDENTIFICATION 2920-016A-N DISC SEALER

MANUFACTURED 06-01-2021 TO PRESENT

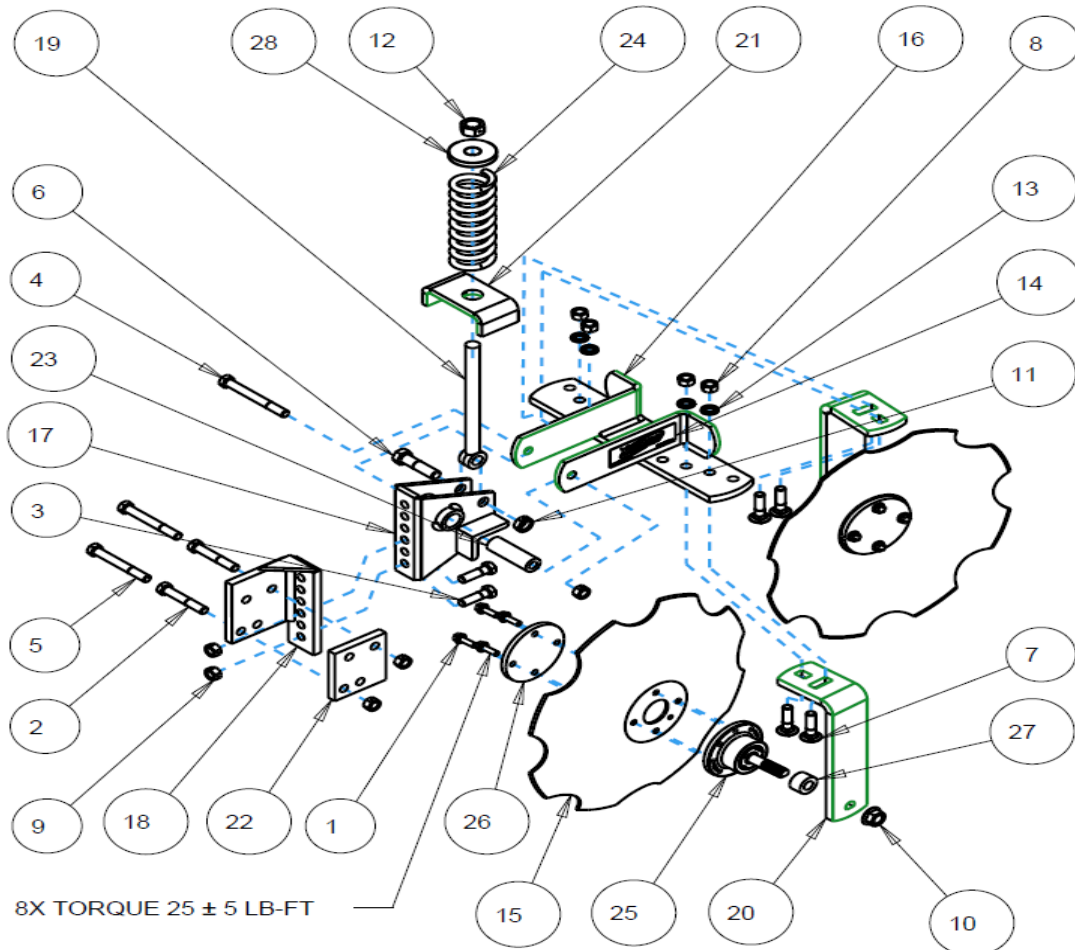

ITEM	PART NO	DESCRIPTION	QTY
1	2502-221	5/16-18 X 1 HHFS GRADE 5	8
2	2502-313	1/2-13 X 3 HHCS GRADE 5	2
3	2502-317	1/2-13 X 1-3/4 HHCS GRADE 5	2
4	2502-363	1/2-13 X 4-1/2 HHCS GRADE 5	1
5	2502-364	1/2-13 X 4 HHCS GRADE 5	2
6	2502-393	5/8-11 X 2-1/2 HHCS GRADE 5	1
7	2505-345	1/2-13 X 2 CARRIAGE BOLT GRADE 5	4
8	2520-352	1/2-13 HEX NUT GRADE 2	4
9	2520-357	1/2-13 LOCK HEX NUT GRADE A	5
10	2520-465	5/8-11 FLANGE NUT GRADE 8	2
11	2520-467	5/8-11 JAM LOCKNUT	1
12	2520-515	3/4-10 HEX LOCK NUT GRADE A	1
13	2525-352	1/2 LOCKWASHER	4
14	2565-162	YETTER DECAL	2
15	2571-187	NOTCHED DISC 16"	2
16	2920-209	PIVOT ARM	1
17	2920-210	MOUNTING BRACKET	1
18	2920-211	SHANK MOUNT BRACKET	1
19	2920-324	3/4" EYEBOLT WITH 5/8" EYE	1
20	2920-329	ARM	2
21	2920-330	SPRING BRACKET	1
22	2920-339	CLAMP PLATE SHANK MOUNT	1
23	2920-342	INNER PIVOT BUSHING	1
24	2920-350	SPRING	1
25	2965-501	HUB ASSEMBLY 2.406 SPINDLE	2
26	2965-503	HUB CAP	2
27	2967-302	SPACER 3/4"	2
28	2975-302	SPRING BUSHING	1



# PARTS IDENTIFICATION

MANUFACTURED 07-01-1997 TO 06-01-2021

- 2920-012 DISC SEALER
- 2920-015 DISC SEALER
- 2920-016 DISC SEALER
- 2920-016-N DISC SEALER W/NOTCHED BLADE
- 2920-016-ST DISC SEALER W/SHARK TOOTH
- 2920-021 DISC SEALER FOR 2995/2996

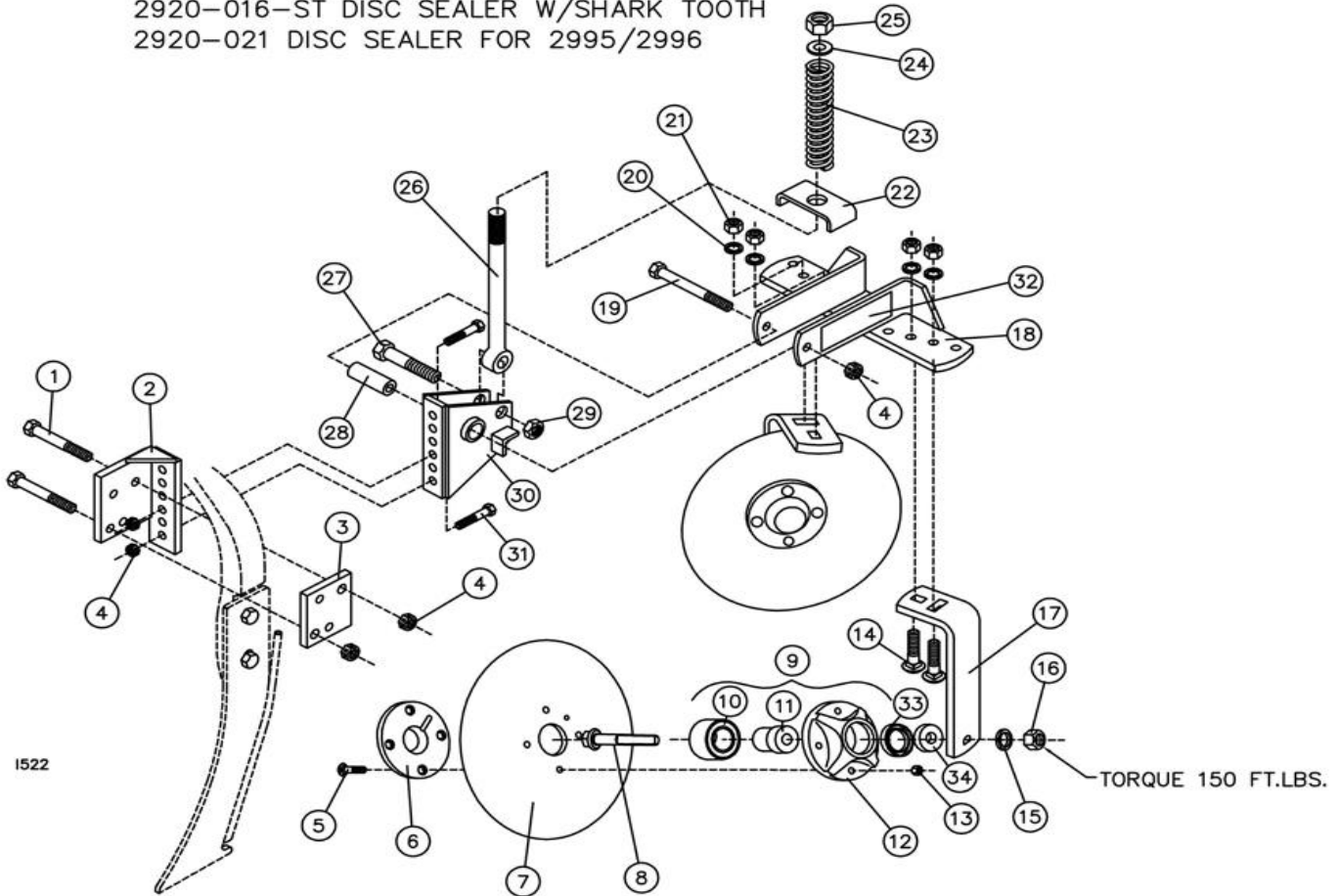

1522

TORQUE 150 FT.LBS.

DET	QTY	PART NO.	DESCRIPTION	DET	QTY	PART NO.	DESCRIPTION
1	2	2502-313	1/2-13 X 3 HHCS GR. 5 ZP.	16	2	2520-452	5/8-11 HEX NUT ZP.
	2	2502-364	1/2-13 X 4 HHCS GR. 5 ZP.	17	2	2920-329	DISC SEALER BRACKET
2	1	2920-211	SHANK MTG. BRACKET W.A.	18	1	2920-209	DISC SEALER ARM W.A.
3	1	2920-339	SHANK MTG. CLAMP PLATE	19	1	2502-363	1/2-13 X 4 1/2 HHCS GR. 5 ZP.
4	5	2520-357	1/2-13 HEX LOCK NUT ZP.	20	4	2525-352	1/2 MED LOCKWASHER ZP.
5	8	2505-207	5/16-18 X 1 1/4 CAR. BLT. GR. 5 ZP.	21	4	2520-352	1/2-13 HEX NUT ZP.
6	2	2965-352	HUB CAP CASTING, 4 BOLT, BLACK	22	1	2920-330	DISC SEALER SPRING BRACKET
7	2	2571-173	.138 X 16" DISC, 4 BOLT	23	1	2920-350	COMP. SPRING, .393 W, 1 5/8" ID
	2	2571-181	.098 X 12" DISC, 4 BOLT	24	1	2975-302	2975 SPRING BUSHING
	2	2967-404	13" TAPER TOOTH SPOKE WHEEL	25	1	2520-515	3/4-10 LOCK HEX NUT ZP.
	2	2571-187	16" NOTCHED SEALER BLADE	26	1	2920-324	PUSHROD, 9-3/16" EYEBOLT, ZP.
	2	2967-602	13" SHARK TOOTH WHEEL	27	1	2502-393	5/8-11 X 2 1/2 HHCS GR. 5 ZP.
8	2	2570-742	D-BOLT, FLANGE 5/8-11 X 4" GR. 8 ZP.	28	1	2920-342	INNER PIVOT BUSHING, ZP.
9	2	2965-128	HUB AND BEARING ASS'Y., 4 BOLT	29	1	2520-467	5/8-11 JAM HEX LOCK NUT ZP.
10	2	2570-594	BEARING, 2 ROW NTN# DF0654LU	30	1	2920-210	MTG. BRACKET W.A.
11	2	2570-715	BEARING INSERT, TRASHMASTER	31	2	2502-317	1/2-13 X 1 3/4 HHCS GR. 5 ZP.
12	2	2965-351	HUB CAST., MACHINED, 4 BOLT	32	2	2565-162	YETTER DECAL, 1 1/2 X 4 1/2
13	8	N10213	5/16-18 HEX FLANGE SERRATED NUT	33	2	2550-052	SEAL
14	4	2505-345	1/2-13 X 2 CAR. BLT. GR. 5 ZP.	34	2	2967-302	SPACER, 3/4", ZP
15	2	2525-451	5/8 MED LOCKWASHER				

REVISED 12/06/11

### FIELD SERVICE KITS

- 2965-119 - SERVICE KIT FOR 2570-740-2.812 D-BOLT
- 2965-120 - SERVICE KIT FOR 2570-742-3.812 D-BOLT
- 2965-121 - SERVICE KIT FOR 2570-766-2.562 D-BOLT

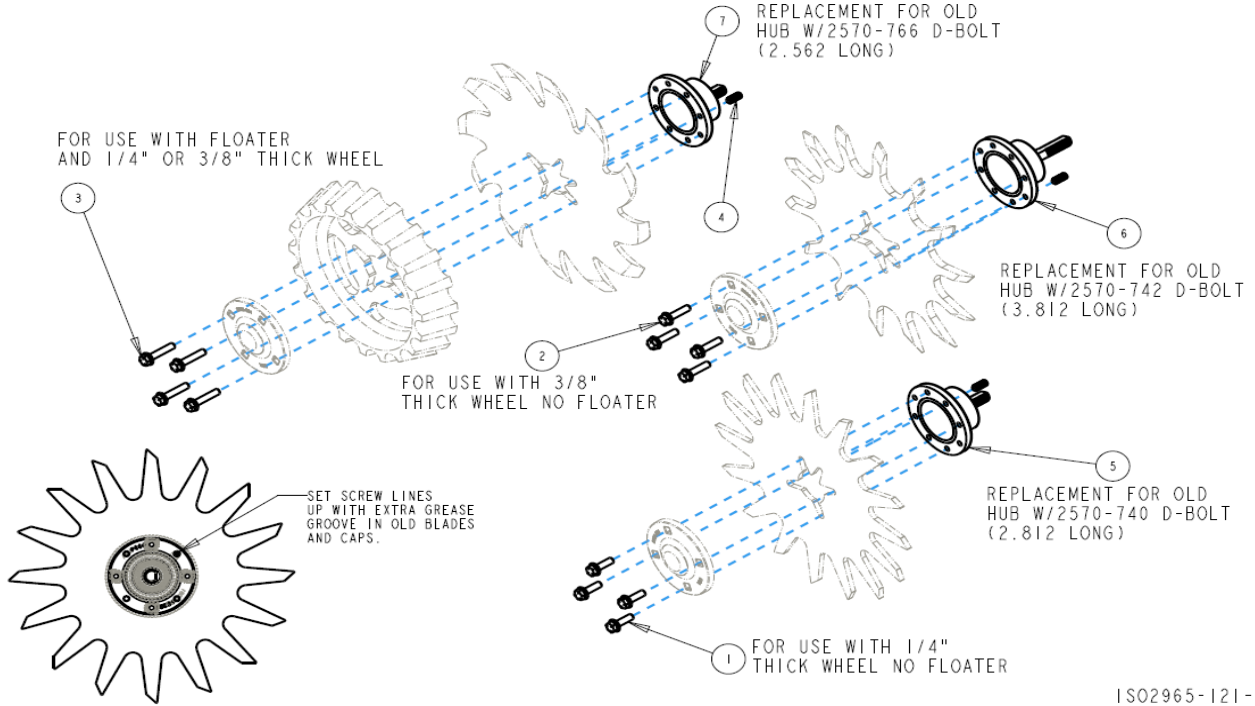

ISO2965-121-2

ITEM	PART NO	DESCRIPTION	QTY
1	2502-221	5/16-18 X 1 HHFS GRADE 5	4
2	2502-222	5/16-18 X 1-1/4 HHFS GRADE 5	4
3	2502-225	5/16-18 X 1-1/2 HHFS GRADE 5	4
4	2940-560	SET SCREW	1
5	2965-500	HUB ASSEMBLY 1.406 SPINDLE	1
6	2965-501	HUB ASSEMBLY 2.406 SPINDLE	1
7	2965-502	HUB ASSEMBLY 1.157 SPINDLE	1

**MUST ALIGN GREASE ZERK WITH ALL GREASE GROOVES**

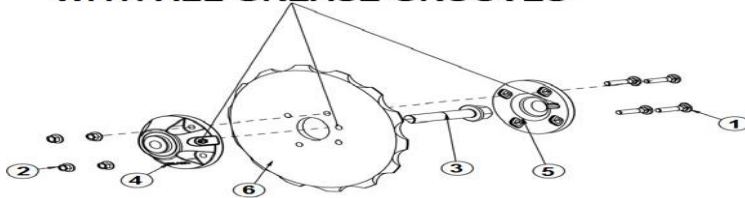

ITEM	PART NO	DESCRIPTION	QTY
1	2505-207	5/16-18 X 1-1/4 CARRIAGE HEAD BOLT GRADE 5	4
2	2520-206	5/16-18 FLANGE LOCK NUT	4
3	2570-742	D-BOLT FLANGE HEAD 5/8-11 X 3.812 GRADE 8	1
4	2965-128	HUB/BEARING ASSEMBLY	1
	2550-069	SEAL	1
	2570-594	BEARING	1
	2570-715	INSERT	1
	2965-351	HUB	1
	2533-110	GREASE FITTING	1
5	2965-352	HUB CAP	1
6	2571-173	16" SMOOTH DISC	1
	2571-181	12" SMOOTH DISC	1
	2571-187	16" NOTCHED DISC	1

## PARTS IDENTIFICATION 2920-023 DIETRICH BRACKET KIT

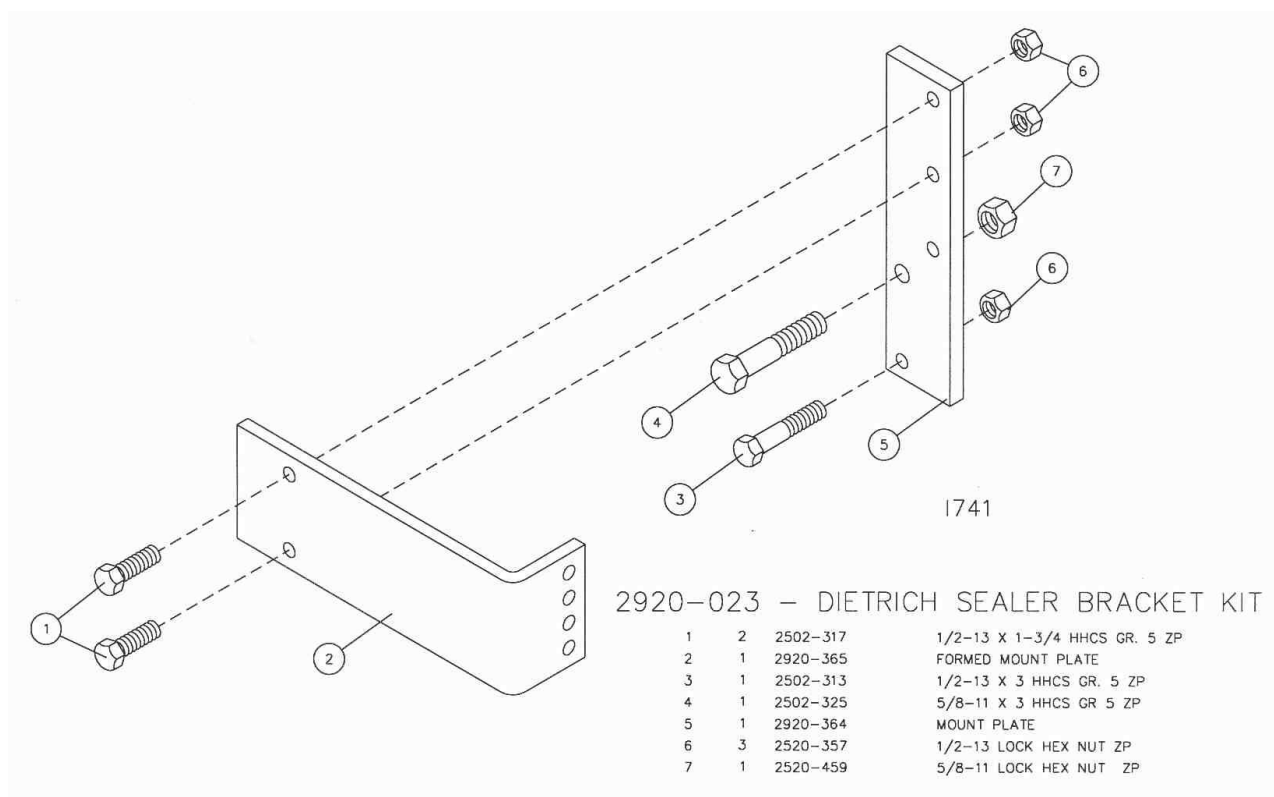

## TROUBLESHOOTING

Problem	Cause	Solution
Poor overall performance.	Toolbar not adjusted correctly	Adjust the toolbar so that during operation it is level.
Max Sealer Plus not creating a mound or too small of a mound.	Speed too slow.	Operate at 5mph min.
	Blades are not set aggressively enough	Increase the angle of the front edge of blade to the row.
Max Sealer Plus is not closing the knife track.	Blades are not set aggressive enough.	Curved blades the “cup” should be in toward the knife.
	Toolbar is not level-probably nose down	Level toolbar.  Increase the angle of the front edge of the blade.



A Tradition of Solutions since 1930

Yetter Farm Equipment Co

PO BOX 358 109 S. McDonough

Colchester, IL 62326-0358

Phone: 309-776-4111

Toll Free: 800-447-5777

Email: [info@yetterco.com](mailto:info@yetterco.com)

For updated models and manuals visit the Yetter website:

[www.yetterco.com](http://www.yetterco.com)

© Yetter Farm Equipment Co. All Rights Reserved

2565-412\_REV\_H • 02/2023