



2995-014 & 2995-015

T.O.W. KIT R.H. & L.H.

ASSEMBLY INSTRUCTIONS & PARTS MANUAL

2565-717_REV_B 12/2011

2995-014 — T.O.W. KIT, R.H.

2995-015 — T.O.W. KIT, L.H.

KEY	QTY.	PART NO.	DESCRIPTION
1	4	2502-325	5/8-11 X 3 HHCS GR5 ZP (MEII, ME PLUS)
	4	2502-393	5/8-11 X 2-1/2 HHCS GR5 ZP (ME, WHITE, KINZE)
2	8	2526-455	WASHER 21/32" X 1 1/4" X 1/4"
3	1	2995-345	22" CROSS TUBE
4	8	2502-362	1/2-13 X 5 HHCS GR5 ZP
5	4	2995-346	3 X 3.5 CLAMP PLATE
6	8	2520-357	1/2-13 LOCK HEX NUT ZP
7	2	2995-221	REAR MOUNT W.A.
8	4	2520-459	5/8-11 LOCK HEX NUT ZP
** 9	2	2526-453	5/8 SAE FLATWASHER ZP

**PARTS USED ON JD ME II, ME II PLUS

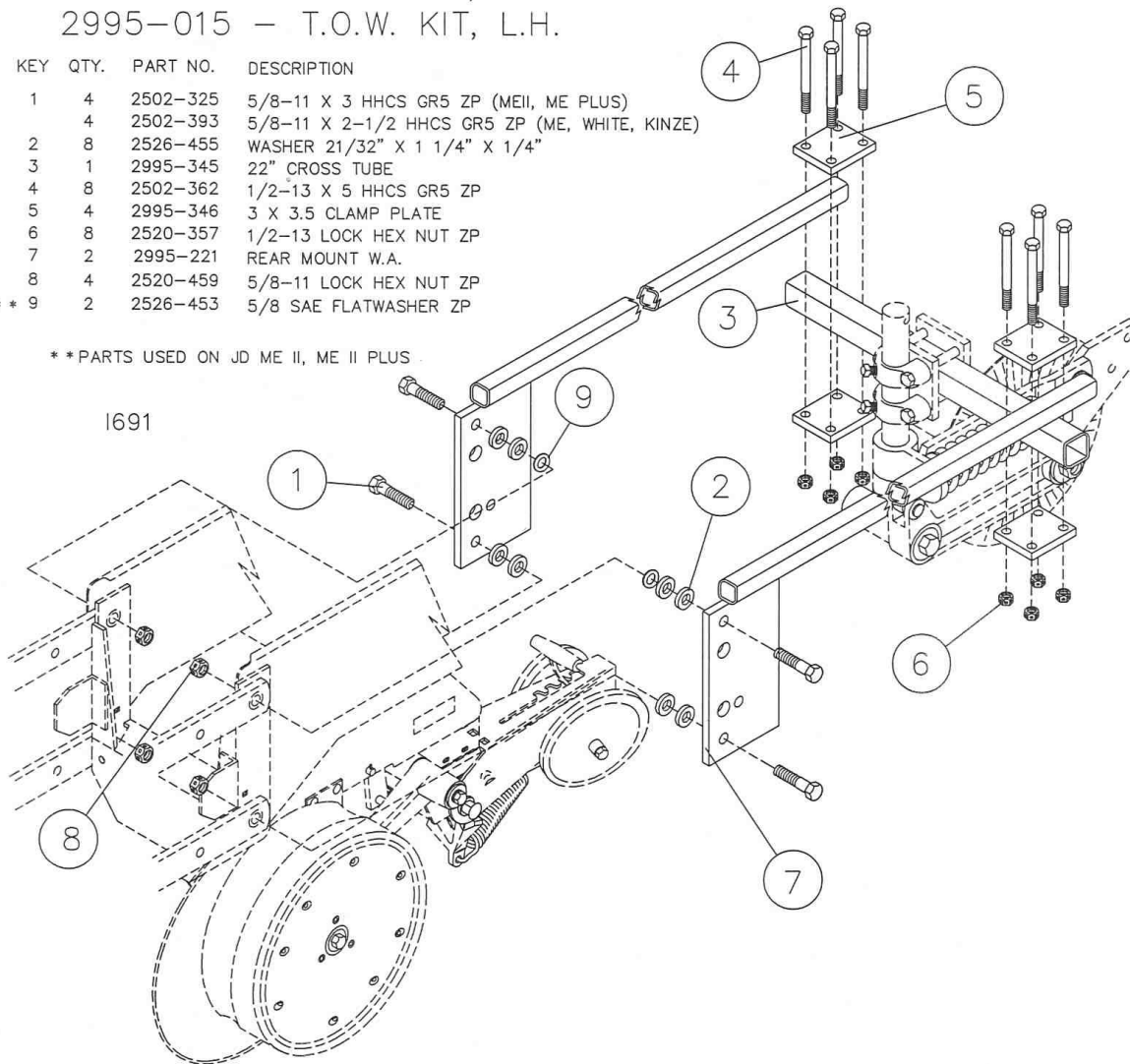

1691

ASSEMBLY INSTRUCTIONS

1. Adjust row unit down pressure springs to the minimum setting, remove planter transport locks and lower the planter frame down to allow the planter row units to just touch ground level.
2. Attach the 2995-221 rear mount brackets to the planter row units using the 5/8" bolts, washer, and lock nuts. NOTE: On Max Emerge (7000), Kinze and White row units use the 5/8" x 2-1/2" bolts and on Max Emerge II (7200) and Max Emerge Plus (1700) row units use the 5/8" x 3" bolts. Fully tighten the 5/8" mounting bolts. Torque to 170 ft. lbs.
3. Clamp the 2995-345 22" cross tube to the 2995-221 rear mount brackets at or near the end of the tubing using the 1/2" x 5" bolts, 2995-346 clamp plates and lock nuts.
4. Locate the row unit center and make a mark on the cross tube. Knowing the distance off of the row center that you want to place the fertilizer, measure that distance and make a mark on the cross tube. Now attach the attach the 2990-153 clamp kit to the front of the cross tube and center the clamp on the mark where the fertilizer is to be placed. NOTE: It is best to consult the fertilizer supplier for spacing requirements when placing starter fertilizer close to the seed.

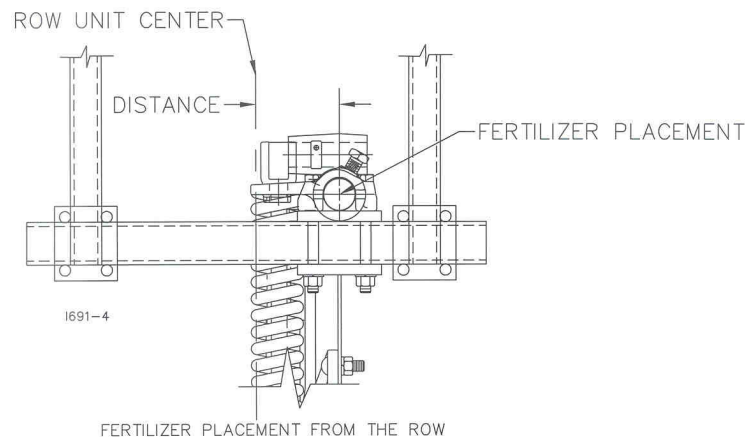

5. Install the 2530-208, 3/8" x 2 1/2" roll pin into the end of the 1-1/2" round shank, leaving equal amount of the roll pin protruding out each side.
6. Insert the 2975-303 locking collar into the coulters pivot casting and slide the 22" shank up through the casting and locking collar. Allow the coulters to pivot, do not align the roll pin with the slots in the casting. Slide the shank until the roll pin has a 1/16" clearance with the casting. Install and slightly tighten the 5/8" x 1" cupped set screw in the lock collar onto the shank.
7. Install the coulters into the clamp kit by installing the shank up through the clamp casting, hold the shank in place using the cotter pin on top of the clamp casting. Install and triple tighten two 5/8" x 1" cupped set screws into the clamp castings, torque to 110 ft. lbs. Coulters depth can be adjusted by raising or lowering the shank at the clamp kit.
8. Adjust the locking collar to allow the coulters to swivel an equal distance left and right. Triple tighten the 5/8" x 1" cupped set screw on the locking collar, torque to 110 ft. lbs.

ASSEMBLY INSTRUCTIONS

9. Lubricate the coultter with grease before using.

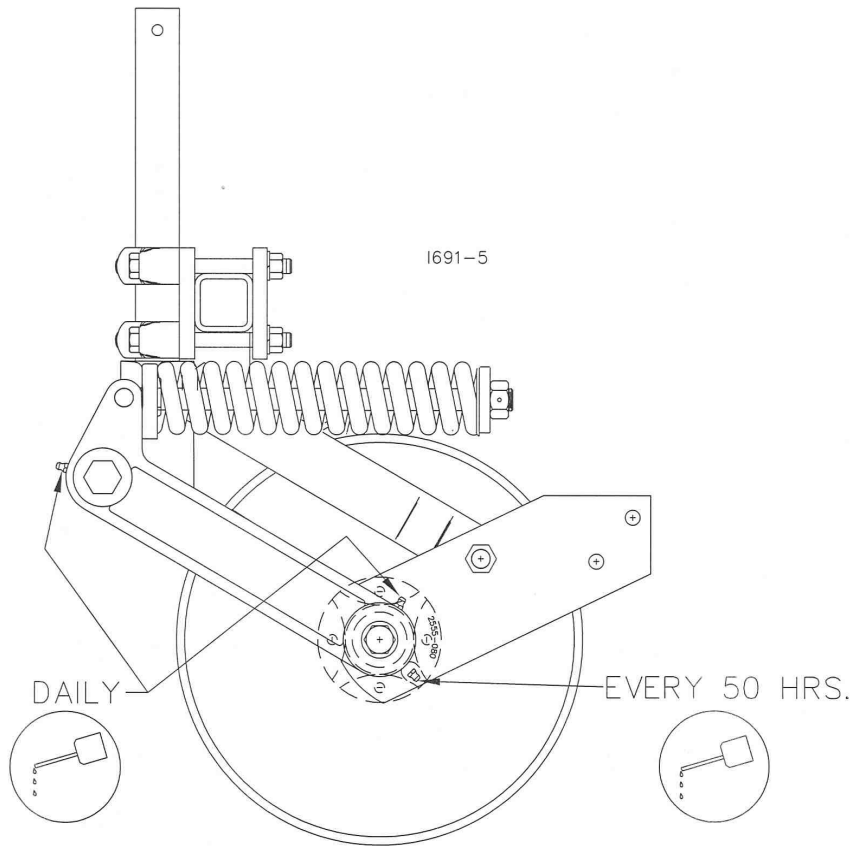

10. After a two hour use, check all bolts and set screws for tightness. Check again after 20 hours of use.

PARTS IDENTIFICATION

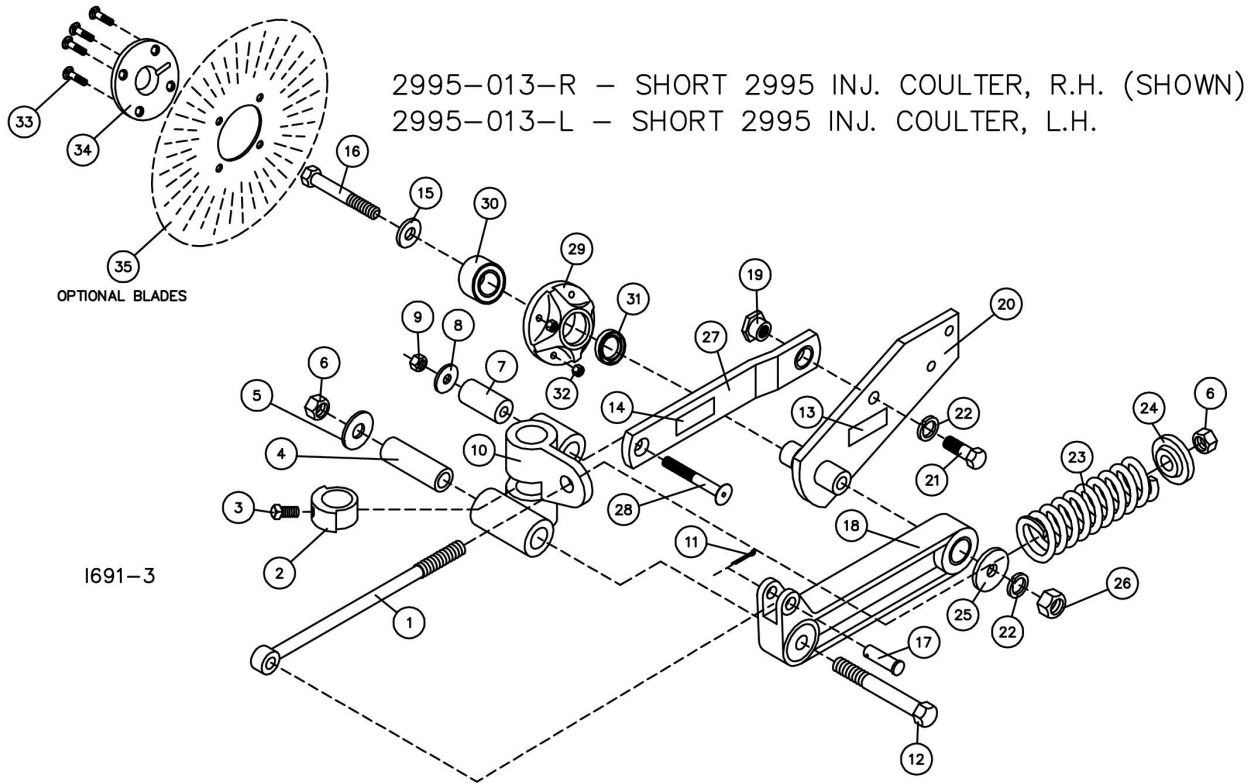

DET	QTY	PART NO.	DESCRIPTION	DET	QTY	PART NO.	DESCRIPTION
1	1	2920-324	PUSHROD 9-3/16	19	1	2570-762	UPPER ARM PIVOT/WASHER ZP
2	1	2975-303	LOCKING COLLAR	20A	1	2995-220	R.H. KNIFE ARM W.A. (SHOWN)
3	1	2503-379	5/8-11 X 1 SQ. HCPSS GR.5 ZP.	20B	1	2995-219	L.H. KNIFE ARM W.A.
4	1	2570-704	PIVOT SLEEVE	21	1	2502-339	5/8-18 X 1 1/2 HHCS GR.5 ZP.
5	1	2527-532	25/32 X 2 X 10 GA MA. BU., ZP	22	2	2525-451	5/8 MED. LOCK WASHER ZYD
6	2	2520-515	3/4-10 LOCK HEX NUT ZYD	23	1	2550-745	UNPAINTED SEALER COMP SPRING
7	1	2995-303	PIVOT SLEEVE, 2-1/2"	24	1	2555-060	SPRING BUSHING CASTING
8	1	2527-340	1/2IDX1 1/2OD X 10 GA MA BU ZP	25	1	2527-529	21/32ID X 2 1/4OD X 1/4" MA BU
9	1	2520-357	1/2-13 LOCK HEX NUT ZYD	26	1	2520-452	5/8-11 HEX NUT ZYD
10A	1	2995-307	COULTER PIVOT CASTING, RH (SHOWN)	27	1	2995-111	UPPER COULTER ARM ASSEMBLY
10B	1	2995-306	COULTER PIVOT CASTING, LH	28	1	2502-360	1/2-13 X 4 HSFHCS ZYD
11	1	2531-102	1/8 X 1-1/4 COTTER PIN BLACK	29	1	2965-351	HUB CASTING, MACHINED 4-BOLT
12	1	2502-510	3/4-10 X 6 HHCS GR 5 ZYD	30	1	2570-594	BEARING, 2 ROW NTN# DFO654L
13	1	2565-162	YETTER DECAL, 1-1/2 X 4-1/2	31	1	2550-052	SEAL, CR #13548
14	1	2565-071	PATENT PENDING DECAL	32	4	N10213	5/16-18 HEX FLANGE SERRATED NUT
15	1	2527-530	1.5 OD X 21/32 ID 3/16 TK. MA. BU.	33	4	2505-208	5/16-18 X 1-1/2 CAR BOLT GR5 ZP
16	1	2502-327	5/8-11 X 5 HHCS GR 5 ZYD	34	1	2965-352	HUB CAP CASTING, 4 BOLT, BLACK
17	1	2995-308	SPRING ROD PIN	35	1	2571-014	.140" X 14", 2 BEVEL SMOOTH BLADE
18	1	2995-110	LOWER COULTER ARM ASSEMBLY	1	1	2571-189	.118" X 13" 25 FLUTE BLADE, 4 BOLT
				1	1	2571-022	.118" X 13", 13 WAVE (3.25"BC)

UPDATED 12/09/11

PARTS IDENTIFICATION

DET	QTY	PART NO.	DESCRIPTION
1	1	3010-303	STRAIGHT COULTER SHANK
2	1	2531-161	5/16 X 2 1/2 COTTER PIN ZP
3	1	2995-013-R	13" 2995 STYLE INJ. COULTER, R.H. (SHOWN)
	1	2995-013-L	13" 2995 STYLE INJ. COULTER, L.H.
4	1	2530-208	3/8 X 2 1/2 ROLL PIN ZP
5	1	2503-379	5/8-11 X 1" SQ. HCPSS GR 5 ZYD
6	1	2975-303	2975 LOCKING COLLAR

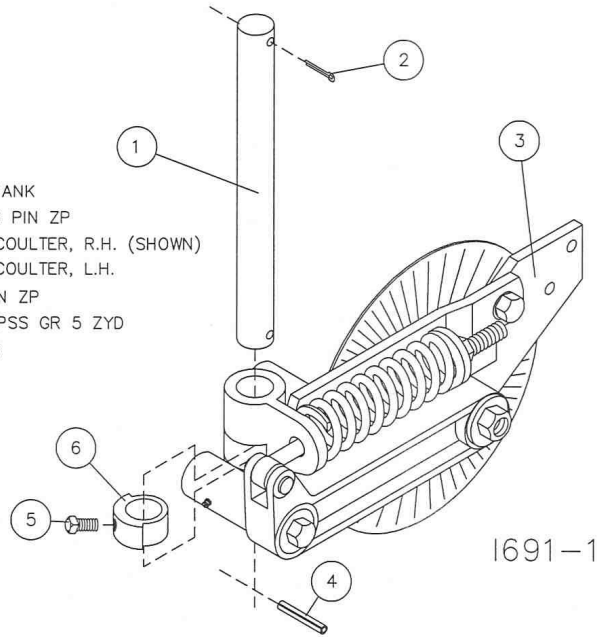

1691-1

2990-153 CLAMP KIT, 2" SQ. BAR

DET	QTY	PART NO.	DESCRIPTION
1	4	2502-362	1/2-13 X 5" HHCS GR 5 ZYD
2	2	2990-363	CLAMP PLATE, 2" SQ. BAR
3	2	2990-360	CLAMP CASTING, DRILLED
4	2	2503-379	5/8-11 X 1" SQ. HCPSS GR 5 ZYD
5	4	2520-357	1/2-13 LOCK HEX NUT ZYD

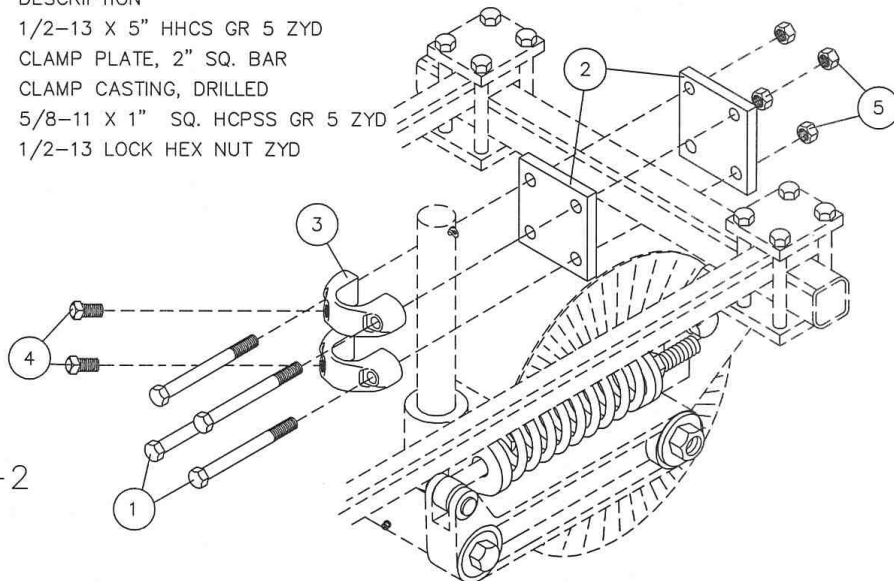

1691-2

2995-109 SPRING MOUNT LIQUID FERTILIZER INJECTOR KIT

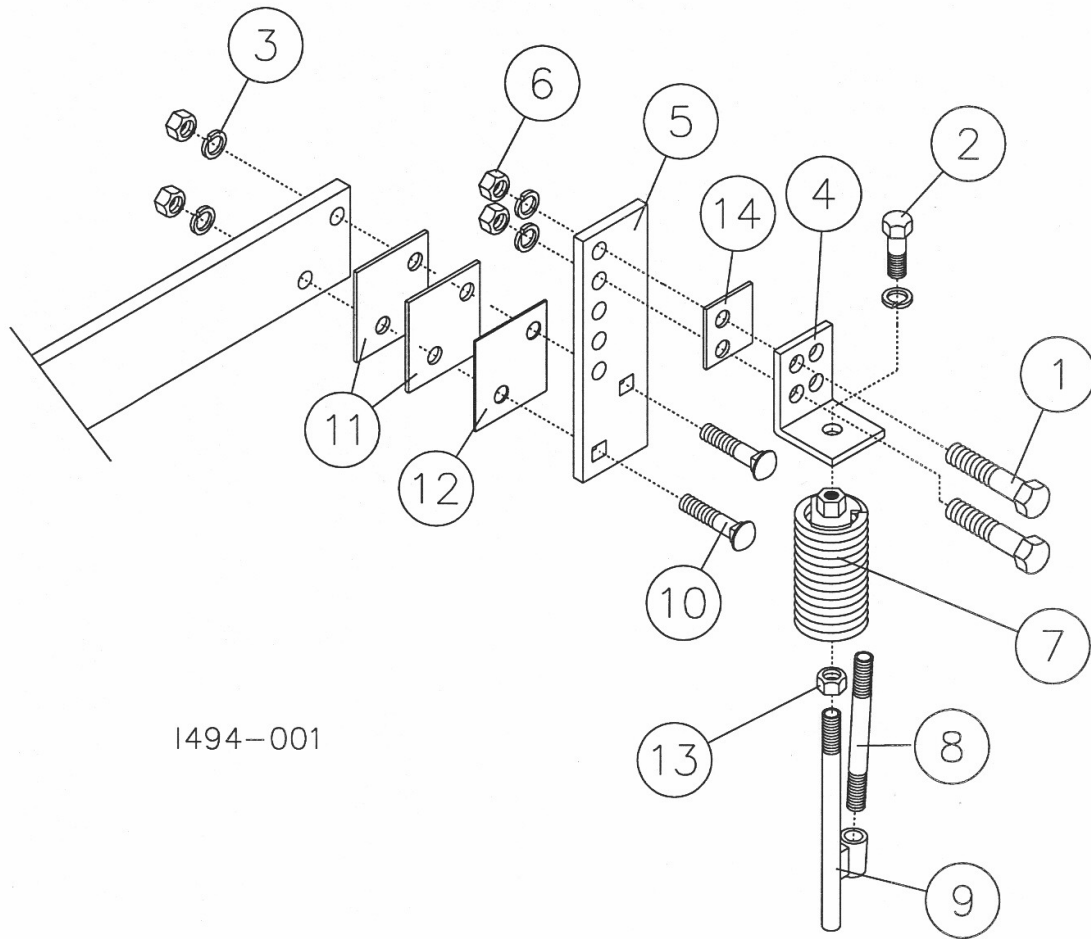

1494-001

2995-109 SPRING MOUNT LIQ. FERT. INJECTOR KIT

KEY	QTY.	PART NO.	DESCRIPTION
1	2	2502-294	1/2-13 X 1 1/2 HHCS GR. 5 ZP
2	1	2502-292	1/2-13 X 1 HHCS GR. 5 ZP
3	5	2525-352	1/2 MED LOCKWASHER ZP
4	1	2995-301	INJECTOR MOUNT PLATE
5	1	2975-389	ADJUSTMENT PLATE, INJECTOR
6	4	2520-352	1/2-13 HEX NUT ZP
7	1	2995-131	SPRING INJECTOR ASSEMBLY
8	1	2515-311	3" NIPPLE, 1/4 NPT STAINLESS STL
9	1	2995-212	INJECTOR ROD W.A., 1/2-13
10	2	2505-345	1/2-13 X 2 CAR. BOLT GR.5 ZP
11	2	2970-319	KNIFE SHIM 1/8" ZP
12	1	2970-320	KNIFE SHIM 16 GA., ZP
13	1	2520-356	1/2-13 JAM HEX NUT ZP
14	1	2995-320	SPACER, INJECTOR

SPRING MOUNT LIQUID FERTILIZER INJECTOR KIT INSTRUCTION

1. Attach adjustment plate (#5) to the straight arm with two 1/2 x 2" carriage bolts in the bottom hole, lockwashers and nuts. Do not tighten, shims may have to be added or taken away to align the injector rod with the coulter blade. Assemble with the head of the bolts on the blade side of the arm. Assemble the injector mount plate (#4) and spacer (#14) to the adjustment plate using the two 1/2 x 1-1/2" bolts, nuts and lockwashers.
2. Assemble the stainless steel pipe nipple to the injector rod w.a. .

NOTE: A female hose barb (not supplied) will be required. Also a straight stream nozzle 1/4 NPT male thread will be required (not supplied). Some operators also install a check valve inline so that fertilizer is not wasted. At the pipe coupler install the appropriate nozzle (not supplied) according to the liquid fertilizer application rate. Nozzles can be ordered through your nearest implement dealer or fertilizer equipment dealer. See the tip application chart in this manual.

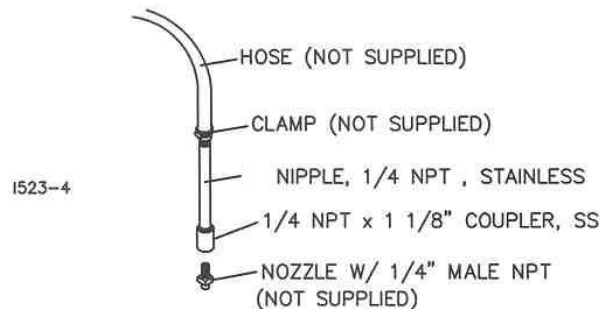

3. Thread a 1/2" hex nut onto the injector rod w.a. with at least 3/4" threads showing. Now thread the spring assembly onto the injector rod. Now jam lock the injector rod to the spring assembly using the 1/2" jam hex nut.
3. Install the injector rod/spring assembly to the injector mount using a 1/2 x 1" bolt and 1/2" lockwasher.
NOTE: The injector rod assembly is to be installed so that the stream nozzle is on the trailing or rear side of the injector rod.
4. Depth is adjusted by selecting a different hole in the adjustment plate.
5. For perfect alignment of injector rod to the coulter blade use the shims, Part #2970-319 & 2970-320.
6. Securely tighten all hardware.
7. After four hours of use, inspect the assembly for loose hardware and re-tighten if necessary.

LIQUID FERTILIZER APPLICATION RATE AND PRESSURE CHART

TABLES ARE BASED ON 30" NOZZLE SPACING

TIP #	LIQUID PRESSURE IN PSI	CAPACITY 1 NOZZLE IN GPM	GALLONS PER ACRE (USING WATER)					
			4 MPH H2O	5 MPH H2O	5.5 MPH H2O	6 MPH H2O	7 MPH H2O	8 MPH H2O
#00015	20	0.11	5.45	4.36	3.96	3.63	3.11	2.72
	25	0.12	5.94	4.75	4.32	3.96	3.39	2.97
	30	0.13	6.44	5.15	4.68	4.29	3.68	3.22
	40	0.15	7.43	5.94	5.40	4.95	4.24	3.71
	50	0.17	8.42	6.73	6.12	5.61	4.81	4.21
60	0.18	8.91	7.13	6.48	5.94	5.09	4.46	
#0002	20	0.14	6.93	5.54	5.04	4.62	3.96	3.47
	25	0.16	7.92	6.34	5.76	5.28	4.53	3.96
	30	0.17	8.42	6.73	6.12	5.61	4.81	4.21
	40	0.20	9.90	7.92	7.20	6.60	5.66	4.95
	50	0.23	11.39	9.11	8.28	7.59	6.51	5.69
60	0.25	12.38	9.90	9.00	8.25	7.07	6.19	
#0003	20	0.21	10.40	8.32	7.56	6.93	5.94	5.20
	25	0.24	11.88	9.50	8.64	7.92	6.79	5.94
	30	0.26	12.87	10.30	9.36	8.58	7.35	6.44
	40	0.30	14.85	11.88	10.80	9.90	8.49	7.43
	50	0.34	16.83	13.46	12.24	11.22	9.62	8.42
60	0.37	18.32	14.65	13.32	12.21	10.47	9.16	
#0004	20	0.28	13.86	11.09	10.08	9.24	7.92	6.93
	25	0.32	15.84	12.67	11.52	10.56	9.05	7.92
	30	0.35	17.33	13.86	12.60	11.55	9.90	8.66
	40	0.40	19.80	15.84	14.40	13.20	11.31	9.90
	50	0.45	22.28	17.82	16.20	14.85	12.73	11.14
60	0.49	24.26	19.40	17.64	16.17	13.86	12.13	
#0005	20	0.35	17.33	13.86	12.60	11.55	9.90	8.66
	25	0.40	19.80	15.84	14.40	13.20	11.31	9.90
	30	0.43	21.29	17.03	15.48	14.19	12.16	10.64
	40	0.50	24.75	19.80	18.00	16.50	14.14	12.38
	50	0.56	27.72	22.18	20.16	18.48	15.84	13.66
60	0.61	30.20	24.16	21.96	20.13	17.25	15.10	
#0006	20	0.42	20.79	16.63	15.12	13.66	11.68	10.40
	25	0.47	23.27	18.61	16.92	15.51	13.29	11.63
	30	0.52	25.74	20.59	18.72	17.16	14.71	12.87
	40	0.60	29.70	23.76	21.60	19.80	16.97	14.85
	50	0.67	33.17	26.53	24.12	22.11	18.95	16.58
60	0.74	36.63	29.30	26.64	24.42	20.93	18.32	
#0008	20	0.57	28.22	22.57	20.52	18.81	16.12	14.11
	25	0.63	31.19	24.95	22.68	20.79	17.82	15.59
	30	0.69	34.16	27.32	24.84	22.77	19.52	17.08
	40	0.80	39.60	31.68	28.80	26.40	22.63	19.80
	50	0.89	44.06	35.24	32.04	29.37	25.17	22.03
60	0.98	48.51	38.81	35.28	32.34	27.72	24.26	
#0010	20	0.71	35.15	28.12	25.56	23.43	20.08	17.57
	25	0.79	39.11	31.28	28.44	26.07	22.35	19.55
	30	0.87	43.07	34.45	31.32	28.71	24.61	21.53
	40	1.00	49.50	39.60	36.00	33.00	28.29	24.75
	50	1.12	55.44	44.35	40.32	36.96	31.68	27.72
60	1.23	60.89	48.71	44.28	40.59	34.79	30.44	
#0015	20	1.06	52.47	41.98	38.16	34.96	29.98	26.24
	25	1.19	58.91	47.12	42.84	39.27	33.66	29.45
	30	1.30	64.35	51.48	46.80	42.90	36.77	32.18
	40	1.50	74.25	59.40	54.00	49.50	42.43	37.13
	50	1.68	83.16	66.53	60.48	55.44	47.52	41.58
60	1.81	89.60	71.68	65.16	59.73	51.20	44.80	

ROW SPACING MULTIPLIER	10" X 3.3	15" X 2.0	18" X 1.66	20" X 1.5	36" X .83	38" X .79	40" X .75
------------------------	-----------	-----------	------------	-----------	-----------	-----------	-----------

$$\text{GPA (Per Nozzle)} = \frac{5940 \times \text{GPM}}{\text{MPH} \times \text{W}}$$

$$\text{GPA} = \text{GALLON PER ACRE}$$

$$\text{GPM} = \text{GALLON PER MINUTES}$$

$$\text{MPH} = \text{MILES PER HOUR}$$

$$\text{W} = \text{WIDTH}$$

SOLUTION FACTOR
 28% = H2O/1.13
 32% = H2O/1.15

This table is a reference only. Please calibrate your equipment to insure proper rate of application. The information contained in this issue is offered in good faith by Yetter Mfg. Co. to further the understanding of liquid fertilizer application.

However, the use of the information provided is beyond the control of Yetter Mfg. Co. and in no case shall Yetter Mfg. Co. or any seller of its products be responsible for any damages that may occur from the use of this information.