



**1000 SERIES
GRAIN HANDLING EQUIPMENT
PARTS & SET-UP MANUAL**

2565-787-REV A • 09/2020

AUGER ACE™



YETTER MANUFACTURING CO.
FOUNDED 1930

Colchester, IL 62326-0358
Toll free: 800/447-5777
309/776-3222 (Fax)
Website: www.yetterco.com
E-mail: info@yetterco.com

Yetter

FOREWORD

You've just joined an exclusive but rapidly growing club.

For our part, we want to welcome you to the group and thank you for buying a Yetter Product.

We hope your new Yetter products will help you achieve both increased productivity and increased efficiency so that you may generate more profit. This operator's manual has been designed into six major sections.

Foreword, Safety Precautions, assembly instructions, Operation, parts identification and troubleshooting.

Throughout the manual references may be made to left side and right side. These terms are used as viewed from the operator's seat facing the front of the tractor.



This **SAFETY ALERT SYMBOL** indicates important safety messages in the manual. When you see this symbol, be alert to the possibility of **PERSONAL INJURY** and carefully read the message that follows.

The word **NOTE** is used to convey information that is out of context with the manual text. It contains special information such as specifications, techniques, reference information and other information of a supplementary nature.

The word **IMPORTANT** is used in the text when immediate damage will occur to the machine due to improper technique or operation. Important will apply to the same information as specified by note only of an immediate and urgent nature.

It is the responsibility of the user to read the operator's manual and comply with the safe and correct operating procedure and to lubricate and maintain the product according to the maintenance schedule in the operator's manual.

The user is responsible for inspecting his machine and for having parts repaired or replaced when continued use of the product would cause damage or excessive wear to the other parts.

It is the user's responsibility to deliver his machine to the Yetter dealer who sold him the product for service or replacement of defective parts that are covered by the warranty policy.

If you are unable to understand or follow the instructions provided in the publication, consult you local Yetter dealer or contact:

YETTER MANUFACTURING CO.

309/776-4111

800/447-5777

309/776-3222 (FAX)

Website: www.yetterco.com

E-mail: info@yetterco.com

WARRANTY POLICY

Yetter Manufacturing warrants all products manufactured and sold by it against defects in material. This warranty being expressly limited to replacement at the factory of such parts or products as will appear to be defective after inspection. This warranty does not obligate the Company to bear cost of labor in replacement of parts. It is the policy of the company to make improvements without incurring obligations to add them to any unit already sold. No warranty is made or authorized to be made, other than herein set forth. This warranty is in effect for one year after purchase.

DEALER _____

Yetter Manufacturing warrants its own products only and cannot be responsible for damage to equipment on which mounted.

SAFETY

A brief description of signal words that may be used in this manual:

CAUTION: Used as a general reminder of good safety practices or to direct attention to unsafe practices.

WARNING: Denotes a specific potential hazard.

DANGER: Denotes the most serious specific potential hazard.

SAFETY PRECAUTIONS

You can make your farm a safer place to live and work if you observe the safety precautions given. Study these precautions carefully and insist that those working with you and for you follow them.

Finally, remember this: an accident is usually caused by someone's carelessness, neglect or oversight.



WARNING

Never clean, lubricate or adjust a machine that is in motion. Always lower or block the implement before performing service.

If the machine must be serviced in the raised position, jack or block it up to prevent it from accidentally falling and injuring someone.

Do not allow riders on the tractor or implement.

Use speeds and caution dictated by the terrain being traversed. Do not operate on any slope steep enough to cause tipping or loss of control.

Be sure all personnel are clear of the immediate area before operating.

Read and understand the operator's manual and require all other persons who will operate the equipment to do the same.

Be familiar with all tractor and implement controls and be prepared to stop engine and implements quickly in an emergency.



CAUTION

Consult your implement and tractor operator's manual for correct and safe operating practices.

Beware of towed implement width and allow safe clearance.

FAILURE TO HEED MAY RESULT IN PERSONAL INJURY OR DEATH.

TABLE OF CONTENTS

	PAGE
FORWARD/WARRANTY.....	2
SAFETY INFORMATION.....	3
TABLE OF CONTENTS.....	4
GENERAL INFORMATION/BOLT TORQUE.....	5-6
ASSEMBLY INSTRUCTIONS.....	7-13
1000-004	
1000-005	
1000-006	
OPERATING INSTRUCTIONS.....	14-15
MAINTENANCE.....	16
PART IDENTIFICATION	
1000-004.....	17
1000-005.....	18
1000-006.....	19
1000-101.....	20
2515-336.....	21
3400-374.....	22
6600-111.....	23



GENERAL INFORMATION

BOLT TORQUE

READ THESE INSTRUCTIONS FIRST:

1. Improperly tightened bolts will result in damage, breakage, expense, and down time.
2. Always replace bolts with the specified grade and type.
3. Torque properly before first use of the machine and every 2-4 hours of use until you are sure bolts are staying tight.
4. The chart below is a guide for proper torque. Use it unless a specified torque is called out elsewhere in the manual.
5. Torque is the force you apply to the wrench handle or the cheater bar, times the length of the handle or bar.
6. Use a torque wrench whenever possible.

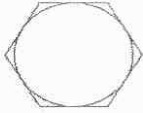
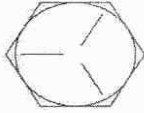
The following table shows torque in ft. lbs.

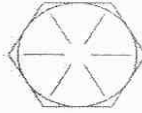
BOLT DIA. AND THREADS PER INCH	 GRADE 2	 OR  GRADE 5 A-325	 GRADE 8
1/4	6	10	14
5/16	12	20	30
3/8 - 16	25	35	50
7/16 - 14	35	55	80
1/2 - 13	55	85	125
9/16 - 12	75	125	175
5/8 - 11	105	170	235
3/4 - 10	185	305	425
7/8 - 9	170	445	690
1-8	260	670	1030
1 1/8 - 7	365	900	1460
1 1/4 - 7	515	1275	2060
1 3/8 - 6	675	1675	2700
1 1/2 - 6	900	2150	3500
1 3/4 - 5	1410	3500	5600

Lubricate all bearings and moving parts as assembled and make certain that they work freely.

GENERAL INFORMATION

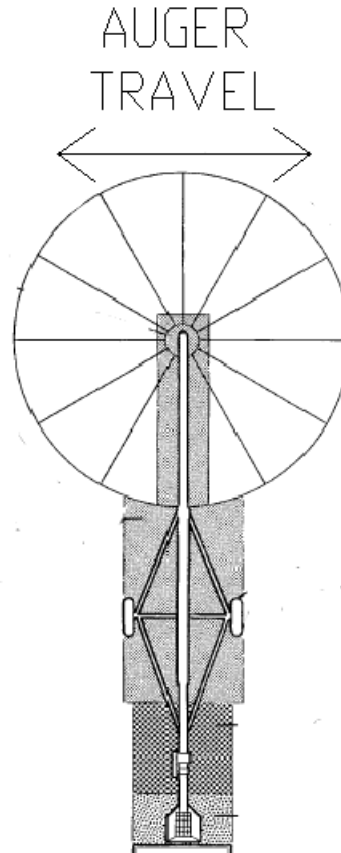

ISD-1000-004-012

WORK AREA: AUGER ACE will move the auger side to side at the discharge end.



KEEP AWAY FROM OVER HEAD WIRES

ASSEMBLY INSTRUCTIONS

STEP 1. Remove the tire/wheel assembly from the Auger.

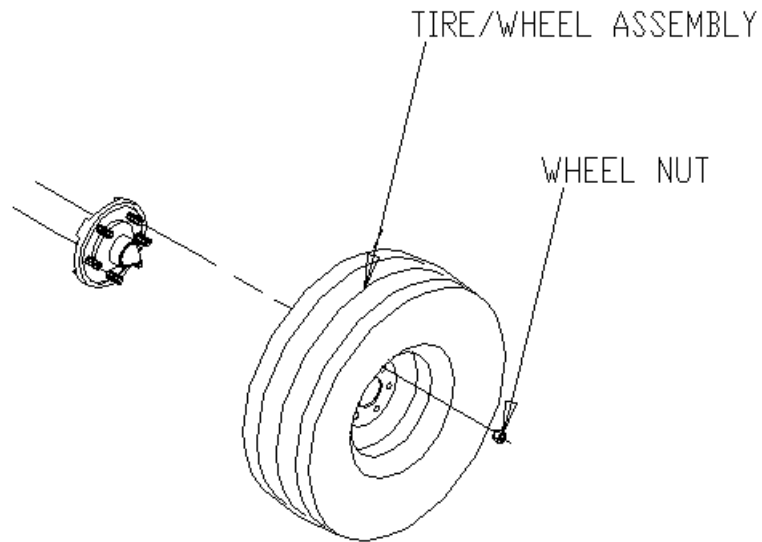

ISD-1000-004-002

STEP 2. Attach the hub adapter plate to the pivot arm using the 5/8" hex head bolts and lock nuts.

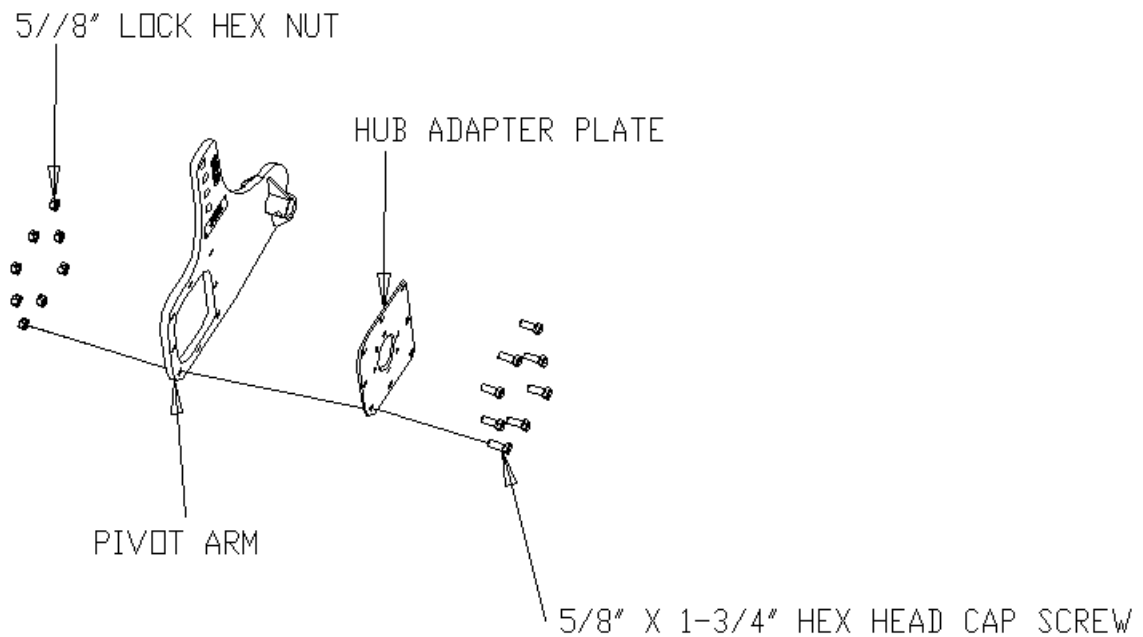

ISD-1000-004-003

ASSEMBLY INSTRUCTIONS

STEP 3: Attach the pivot arm assembly to the auger. Secure with the wheel nuts removed in Step 1. The taper on the wheel nut will face out or away from the adapter plate.

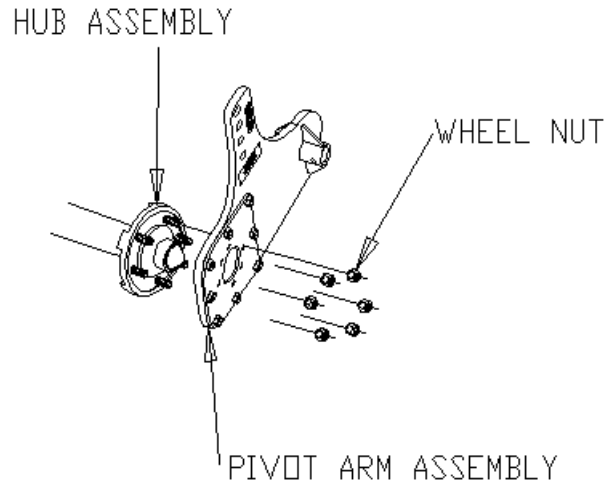

ISD-1000-004-004

STEP 4: Install the hub assembly to the pivot arm with $\frac{1}{2}$ " hex head bolt and lock nut. Attach the wheel assembly and wheel nuts, tighten securely.

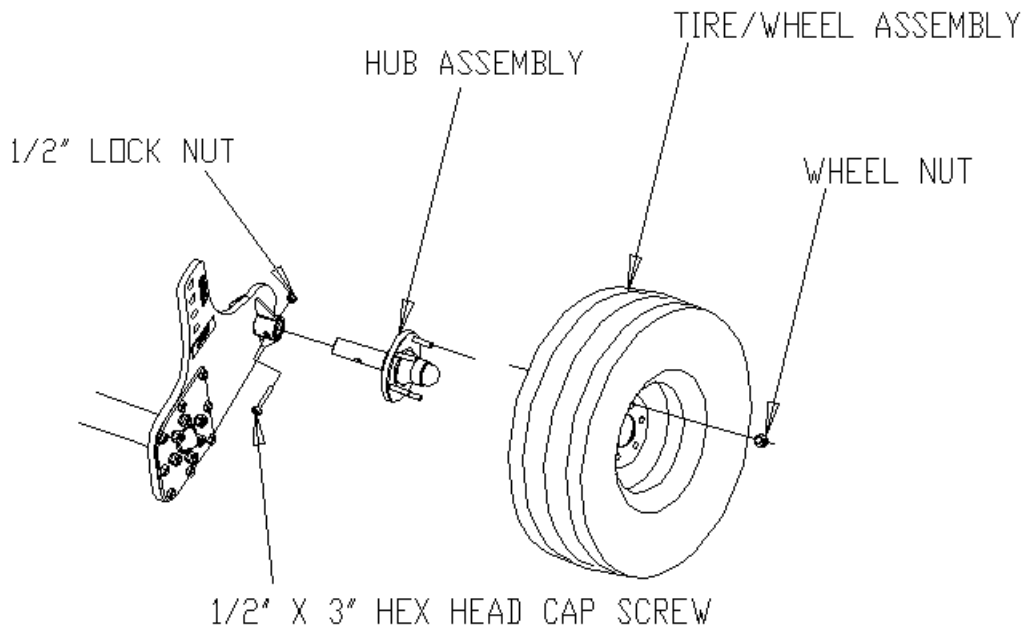

ISD-1000-004-005

ASSEMBLY INSTRUCTIONS

STEP 5: Install the cylinder mount and clamp plate using 4) 5/8" hex head bolts and lock nuts. Leave loose to be able to slide on the auger under carriage.

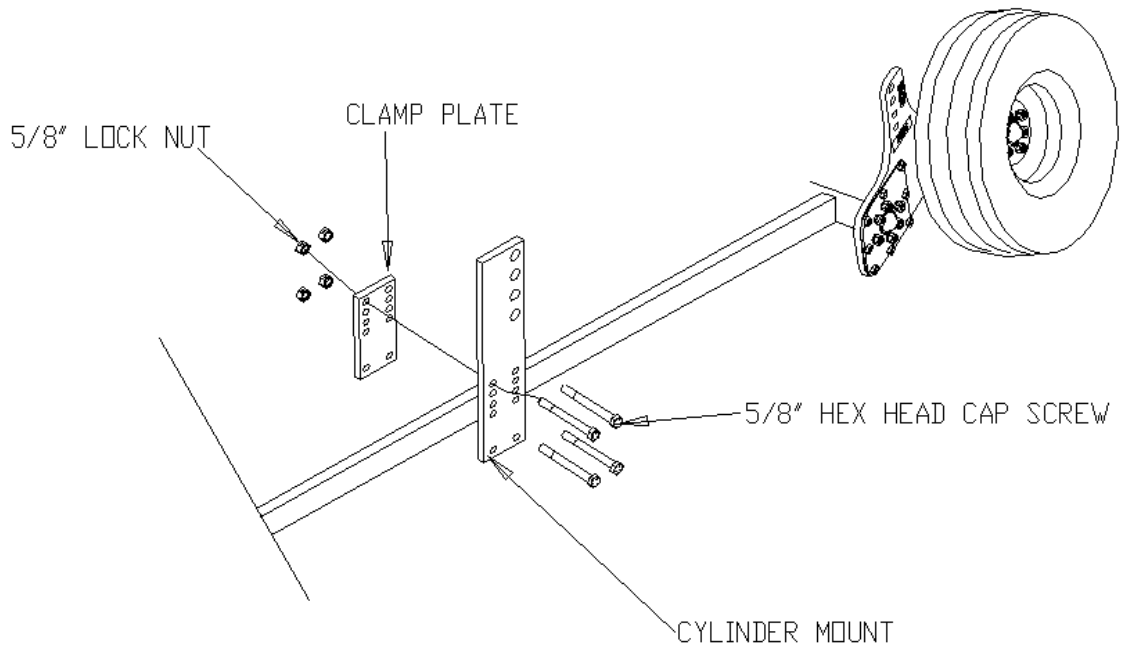

ISD-1000-004-006

STEP 6: Attach the offset hinges to the cylinder mount and pivot arm using the headed pins and hair pins.

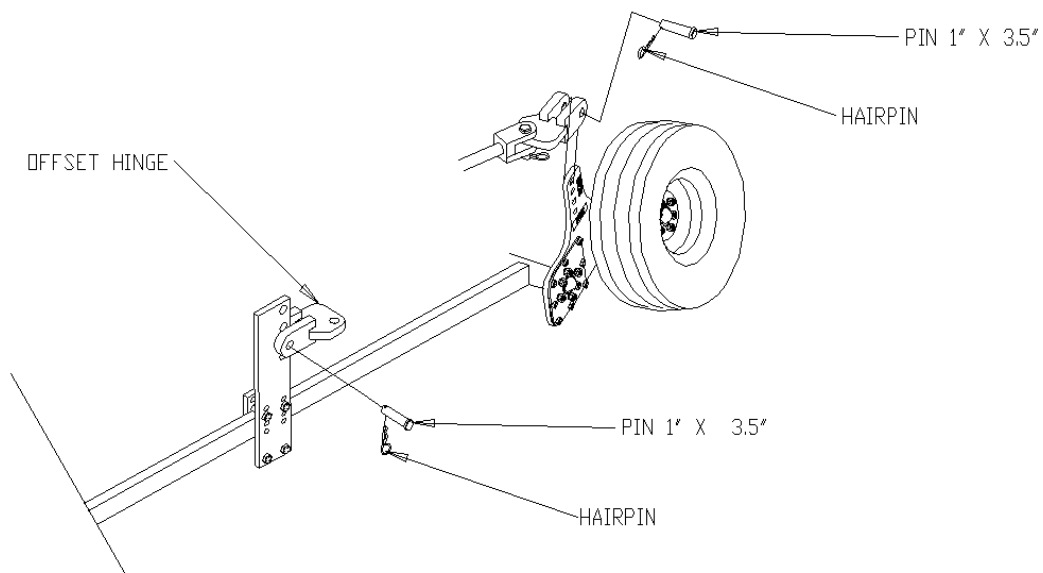

ISD-1000-004-008

ASSEMBLY INSTRUCTIONS

STEP 7: Attach the hydraulic cylinder to the offset hinge at the pivot arm.

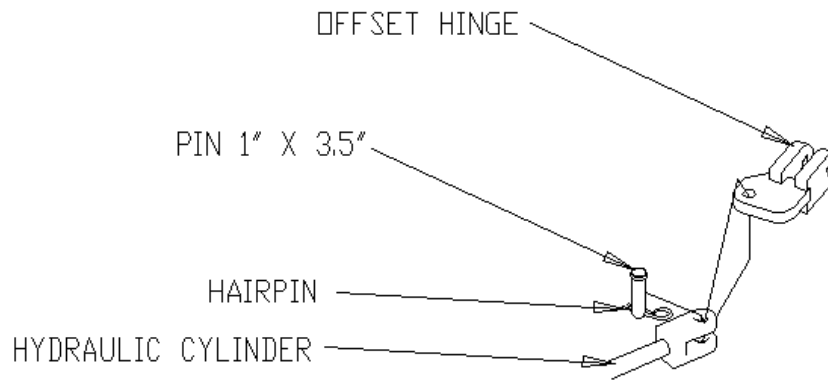

ISO-1000-004-007

ASSEMBLY INSTRUCTIONS

STEP 8: Secure the hydraulic cylinder to the cylinder mount using the headed pin and hair pin.

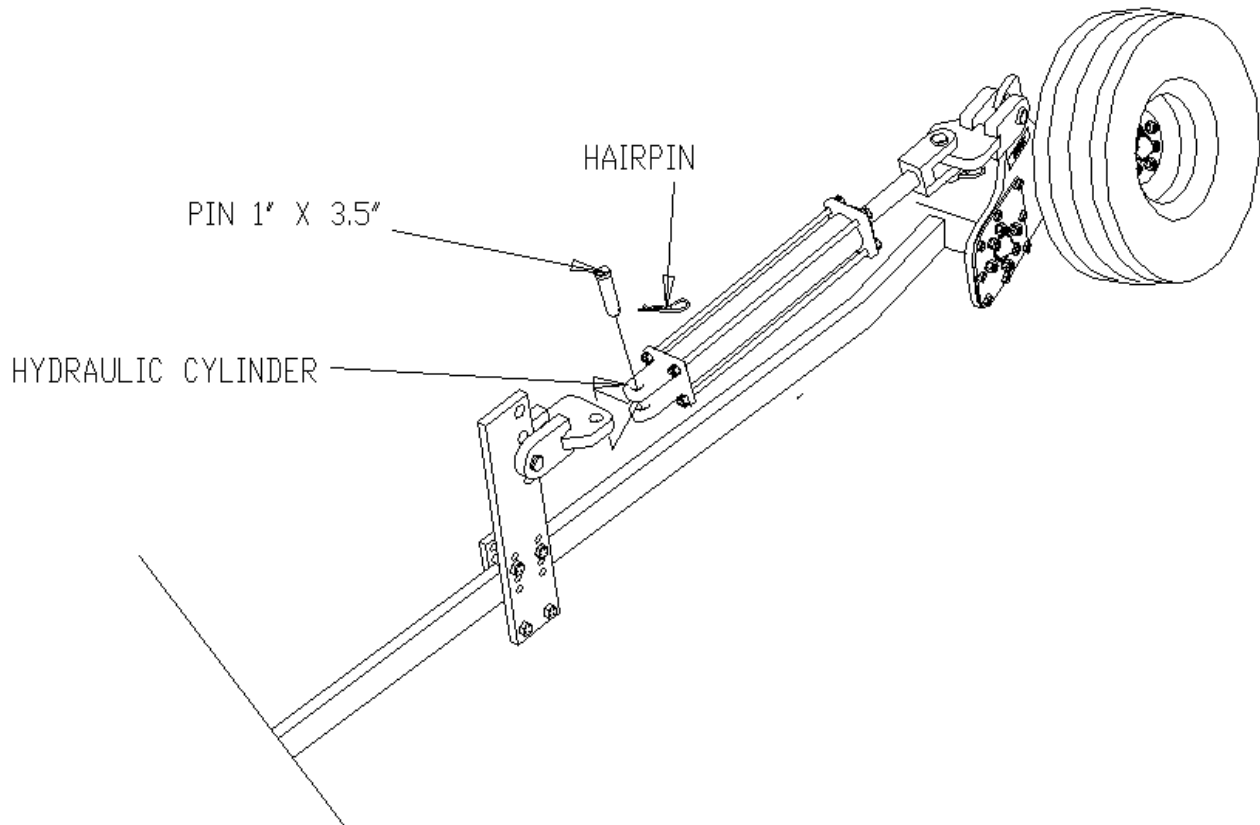

ISD-1000-004-009

ASSEMBLY INSTRUCTIONS

STEP 9: Install the breather valve and ball valve to the hydraulic cylinder

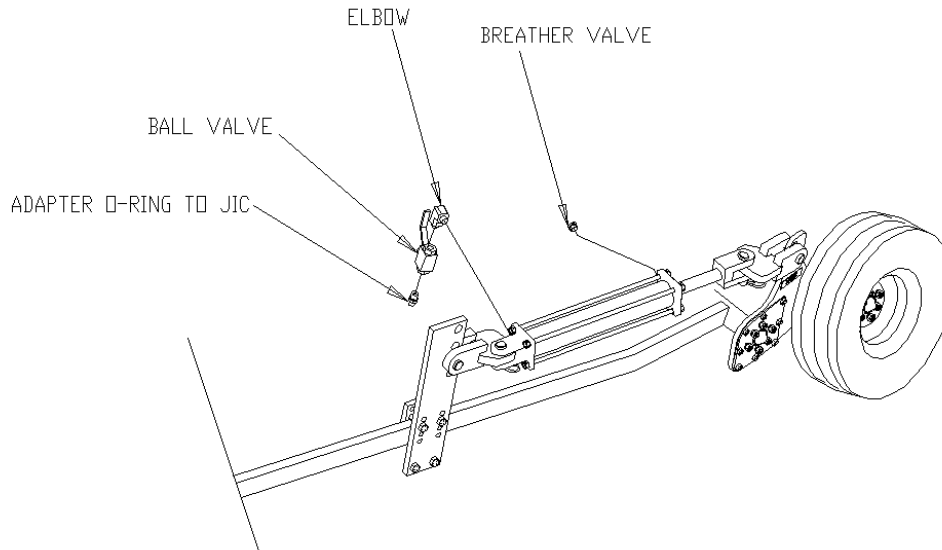

ISO-1000-004-010

STEP 10: ROUTE HYDRAULIC HOSES- HYDRAULIC HOSES NOT SUPPLIED

Secure the hydraulic hoses to the under carriage of the auger. Beware of pinch points.

ASSEMBLY INSTRUCTIONS

STEP 11. Install the ball valve and ISO hydraulic coupler (not supplied) at the tractor. Lubricate the o-rings with oil before assembly of the components.

VALVE AT TRACTOR

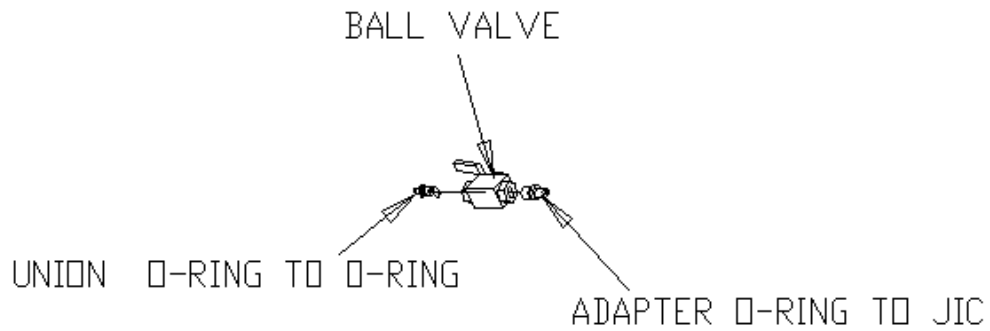

ISO-1000-004-011

ATTACH BALL VALVE TO HYDRAULIC COUPLER AT TRACTOR-COUPLER NOT SUPPLIED

OPERATING INSTRUCTIONS

SAFETY



Overhead Wires,
Power Lines
KEEP AWAY

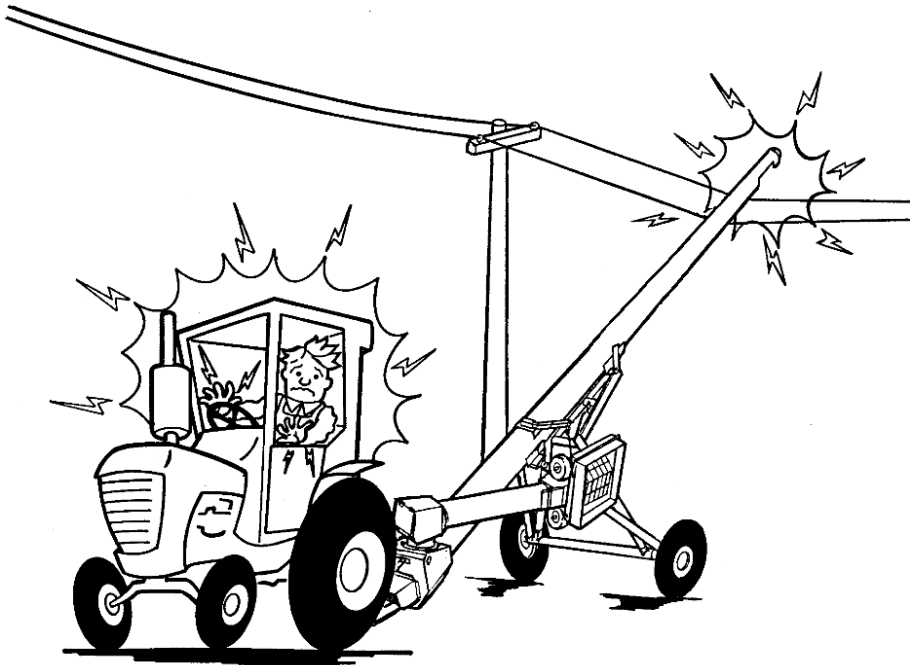

CAUTION! Make sure entire area above auger and the path of travel is clear of overhead obstructions and electrical wires. Failure to do so can result in electrocution (maintain at least 10 feet of clearance from power lines, *electrocution can occur without direct contact of the power lines*).



To prevent tip-over when backing, avoid rolling over any obstructions and avoid steep slopes. If the auger is to be set on a slope, approach the bin uphill. Avoid moving the auger at right angles to a slope.



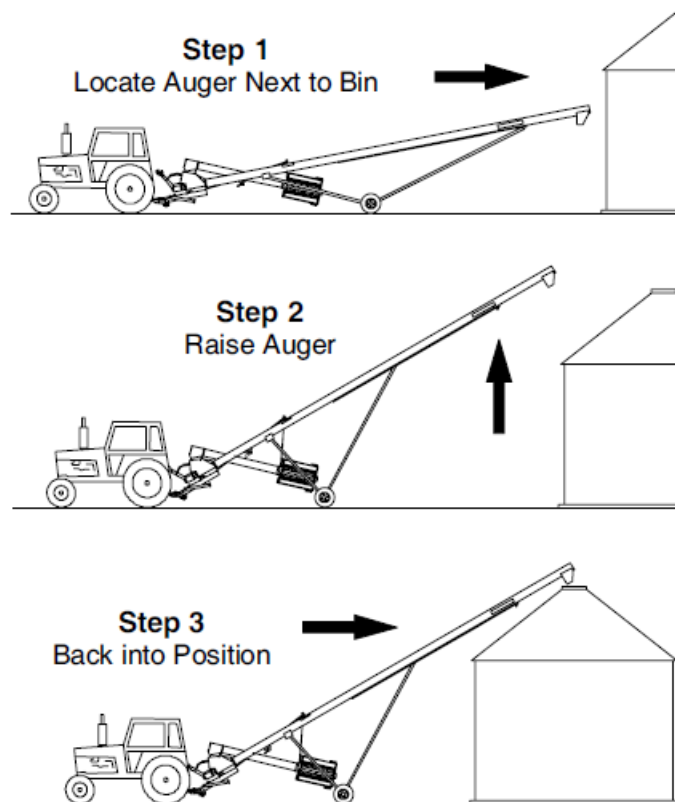

Step 1: Locate Auger Next to Bin

Move the auger into its working position with a towing vehicle. Locate the auger as close as possible to the bin (or other structure). Move auger slowly towards the bin with the towing vehicle – **not by hand**.

Step 2: Raise Auger

Raise the auger only high enough to clear the top of the bin.

Step 3: Back into Position

A: Back auger slowly into working position with the towing vehicle

Do NOT attempt to increase auger height by positioning its wheels on lumber, blocks, or any other means to raise its height.

B: Adjust the auger until the discharge is directly over the opening.*

C: Close the ball valve on the hydraulic hose.

It is good practice to secure the discharge end of the auger to the bin or grain storage structure to prevent possible wind damage (remember to untie the auger before attempting to move).

*When discharging into a grain spreader, maintain at least 12" (305 mm) of space between the auger discharge and the spreader.

MAINTENANCE

Repack
Wheel Bearings
Annually

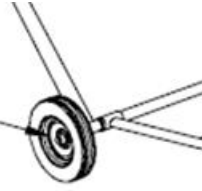

AXLE SPINDLE BEARING

Tapered roller bearings are standard on all augers and should be repacked with grease annually or as needed determined by usage.

1. Raise the undercarriage axle high enough to allow the tire to clear the ground, and support axle with jack stands or equivalent. Never rely solely on hydraulic or mechanical jacks for support, use jack stands or equivalent for support.
2. Remove the dust cover by prying around its edges.
3. Remove the cotter pin, slotted nut and flat washer from the end of the axle shaft. Carefully remove the hub and bearings from the shaft. Inspect all parts for wear or damage and replace as necessary.
4. When reassembling the hub, repack both bearing cones with grease and fill hub cavity 1/3 full..
5. Place inner bearing and seal into hub and carefully reinstall hub onto shaft (be careful not damage the lip of the seal).
6. Install outer bearing into hub and replace the flat washer and slotted nut. Tighten the slotted nut to seal the bearings until the hub binds as you rotate the hub.

Back off the slotted nut to the next slot and install a new cotter pin. Replace dust cap.

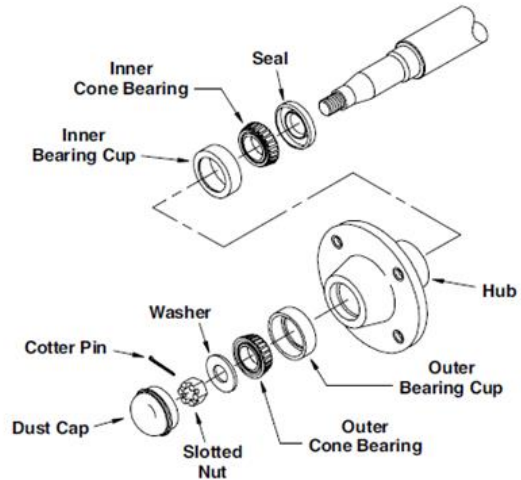

PARTS IDENTIFICATION

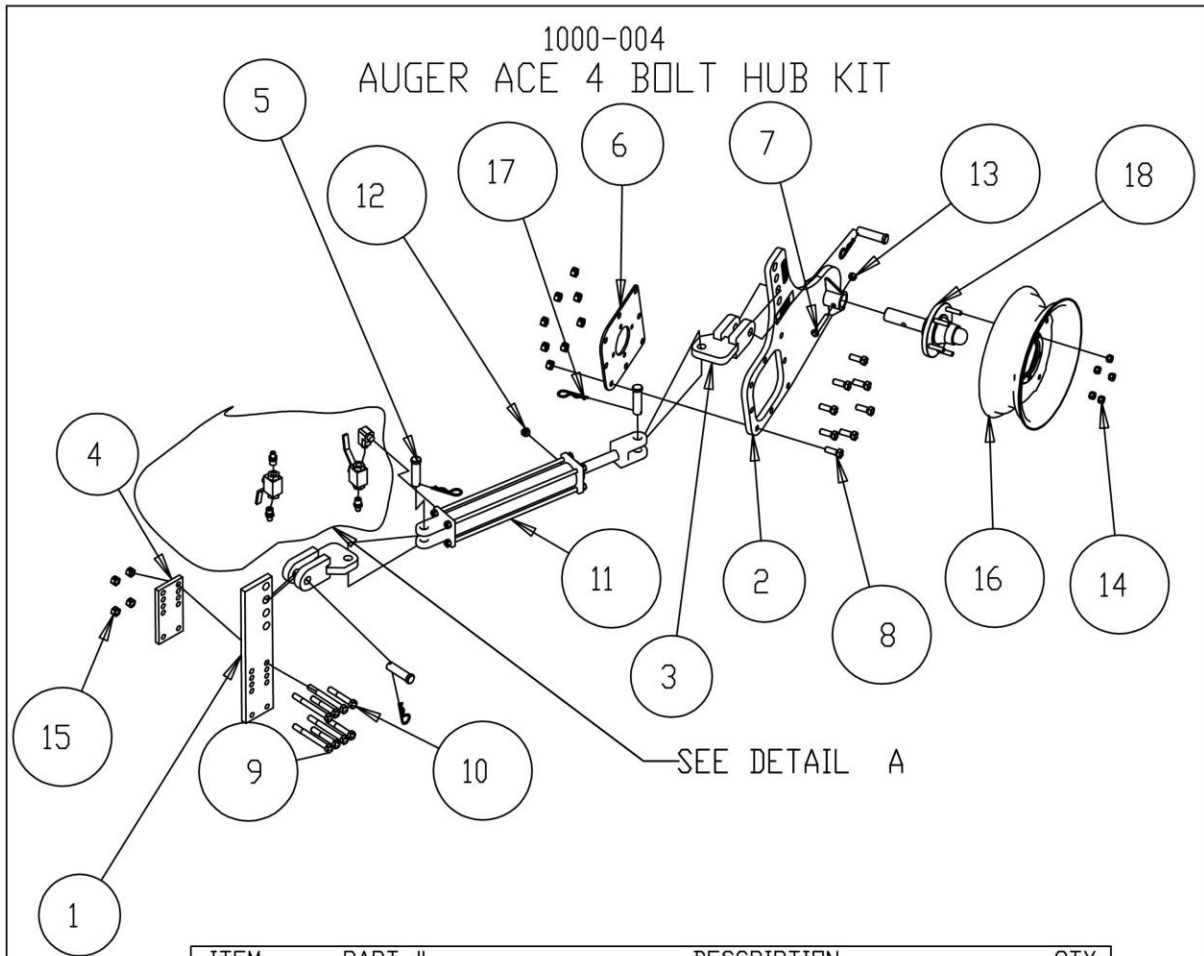

ITEM	PART #	DESCRIPTION	QTY
1	1000-382	CYLINDER MOUNT ADJUSTMENT PLATE	1
2	1000-218	MAIN ARM SHORT	1
3	1000-219	OFFSET HINGE	2
4	1000-383	CLAMP PLATE	1
5	1000-386	PIN 1" X 3.5"	4
6	1000-391	ADAPTER HUB PLATE 4 X 50-3620	1
7	2502-313	1/2"-13 X 3" HEX CAP SCREW GRADE 5	1
8	2502-331	5/8"-11 X 1-3/4" CAP SCREW GRADE 5	8
9	2502-335	5/8"-11 X 6" CAP SCREW GRADE 5	4
10	2502-336	5/8"-11 X 4" CAP SCREW GRADE 5	4
11	2515-336	HYDRAULIC CYLINDER 3" X 16"	1
12	2515-836	BREATHER	1
13	2520-357	1/2"-13 LOCK HEX NUT	1
14	2520-360	1/2"-20 WHEEL HEX NUT	5
15	2520-459	5/8"-11 LOCK HEX NUT	12
16	2570-323	WHEEL 15" X 5"	1
17	2520-465	HAIRPIN	4
18	3400-374	HUB/SPINDLE ASSEMBLY	1

ISO-1000-004_1

PARTS IDENTIFICATION

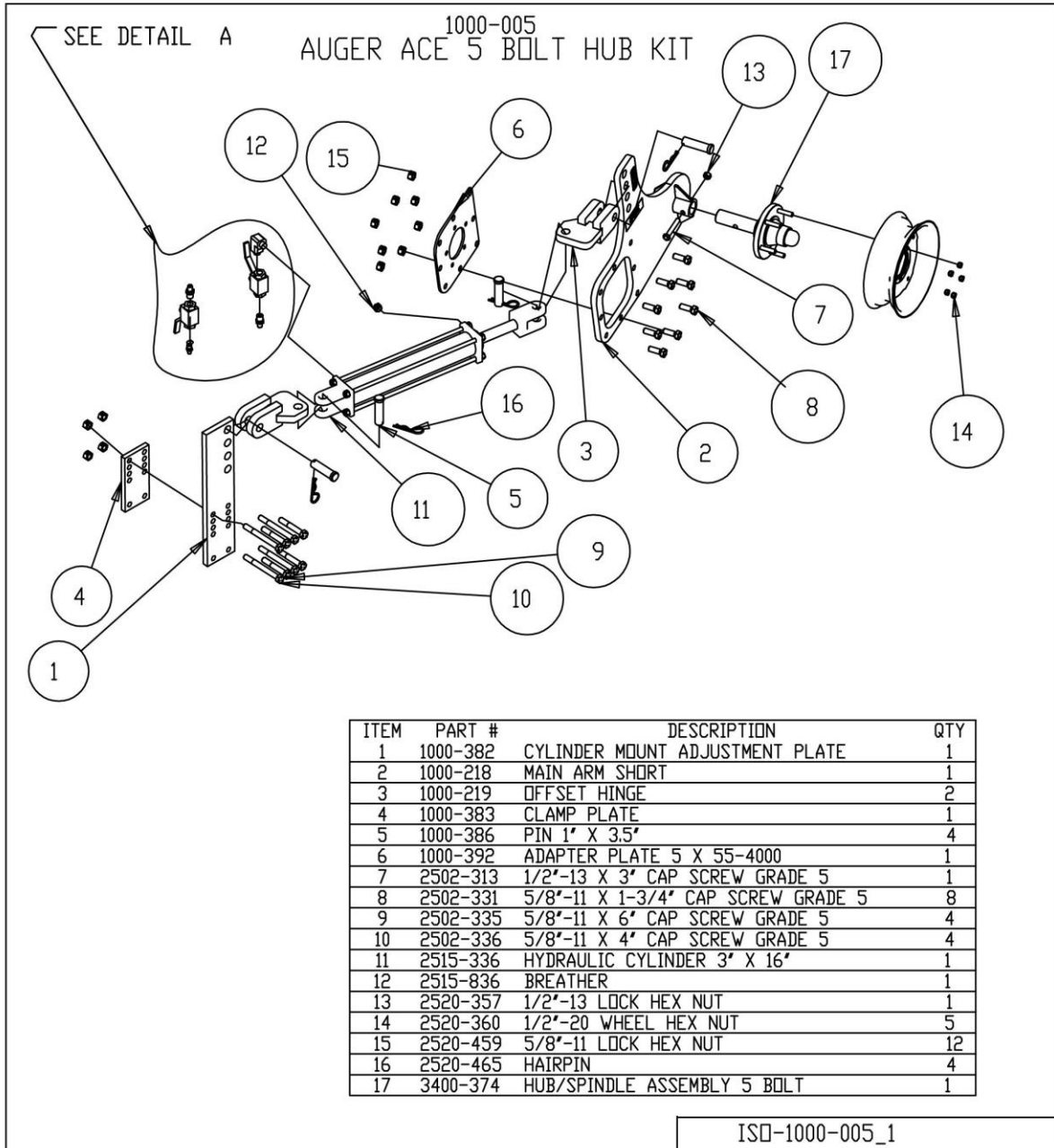

PARTS IDENTIFICATION

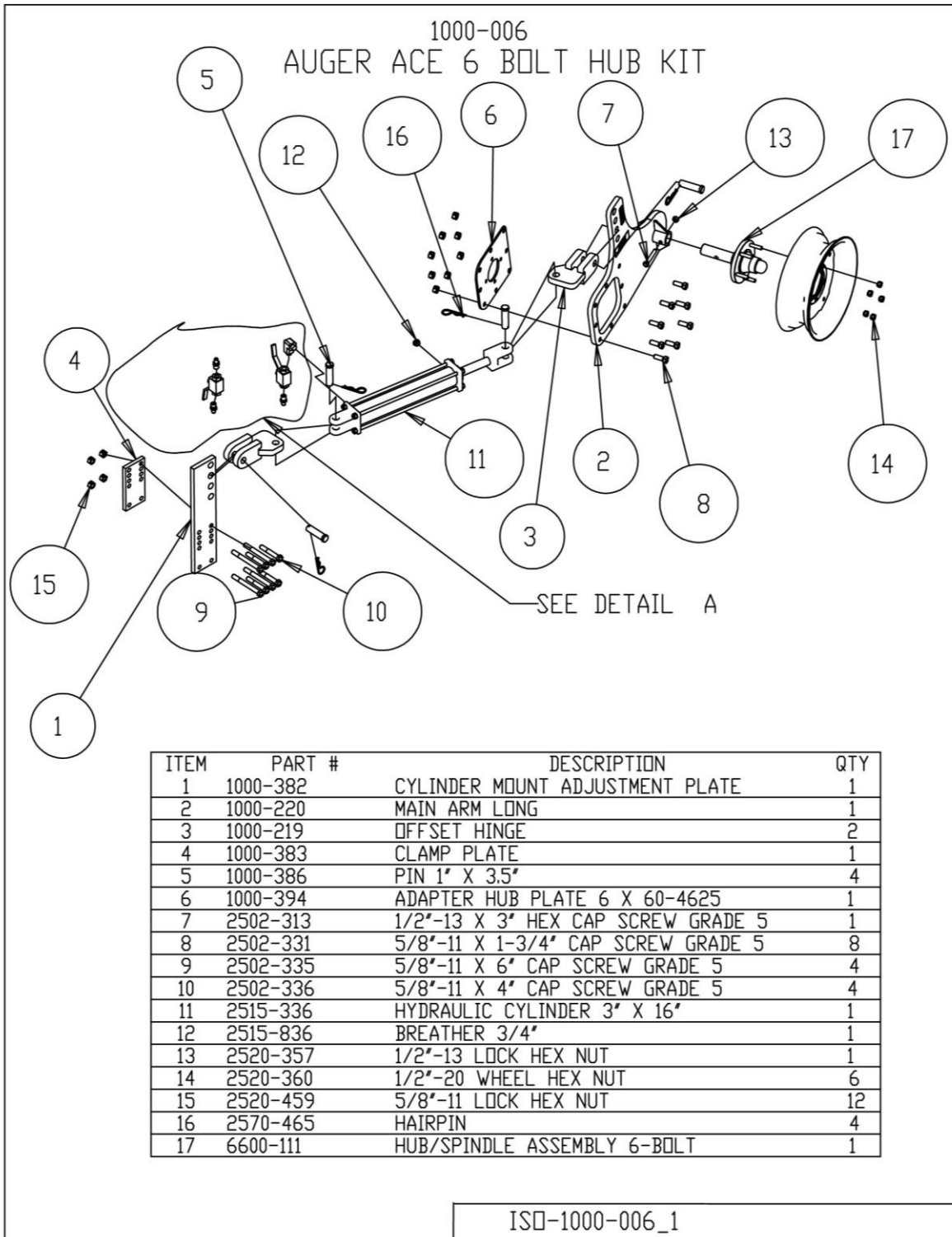

PARTS IDENTIFICATION

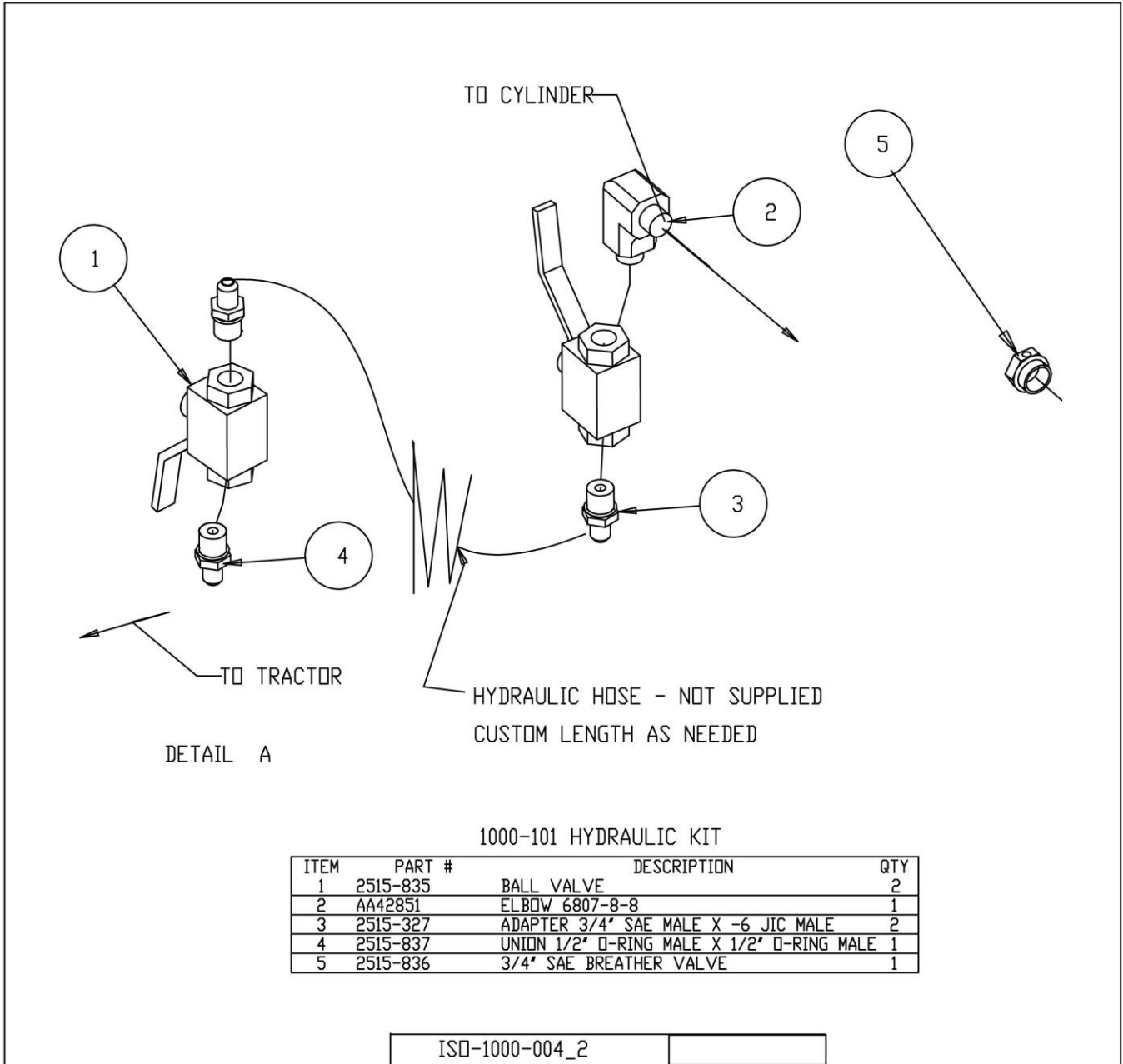

PARTS IDENTIFICATION

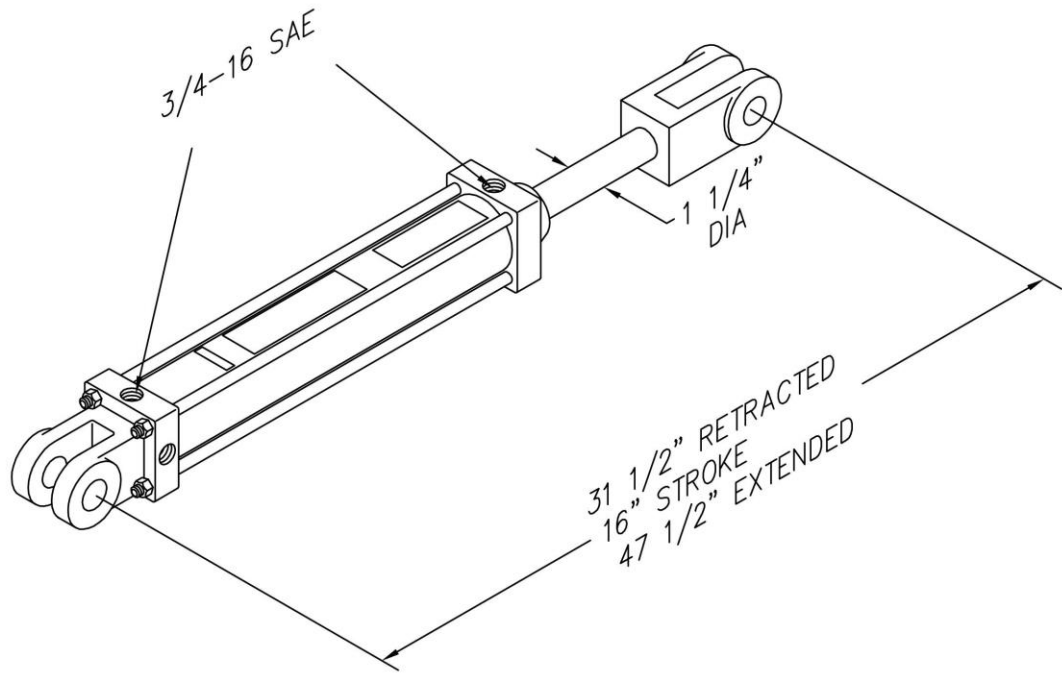

2515-336 3 X 16 CYLINDER

2515-338 REPAIR SEAL KIT

PARTS IDENTIFICATION

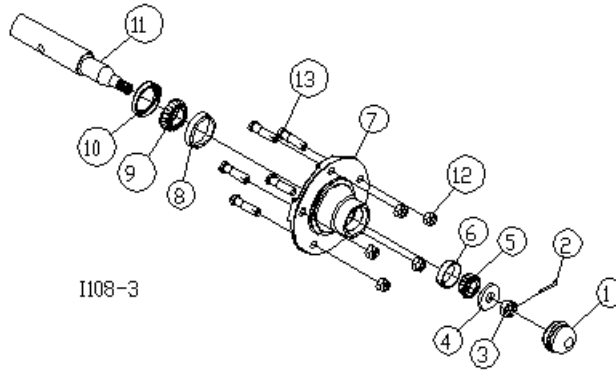

I108-3

3400-374 HUB AND SPINDLE ASSEMBLY

DET	QTY	PART NO.	DESCRIPTION
1	1	2570-308	HUB CAP
2	1	2531-108	5/32 X 1-1/4 COTTER PIN
3	1	2520-469	5/8-18 SLOTTED HEX NUT
4	1	2526-449	5/8 SAE FLATWASHER
5	1	2550-012	CONE (LM-11949)
6	1	2550-013	CUP (LM-11910)
7	1	HUB	4*PILOT 5-1/2" BOLT CIRCLE (NOT A SERVICE PART)
8	1	2550-029	CUP (LM-67010)
9	1	2550-027	CONE (LM-67048)
10	1	2550-115	SEAL (104078)
11	1	3400-378	SPINDLE, 2570-310
12	5	2520-360	1/2-20 WHEEL HEX NUT
13	5	2570-190	1/2-20 X 1.90" HUB BOLT

REVISED 09/09/2020

PARTS IDENTIFICATION

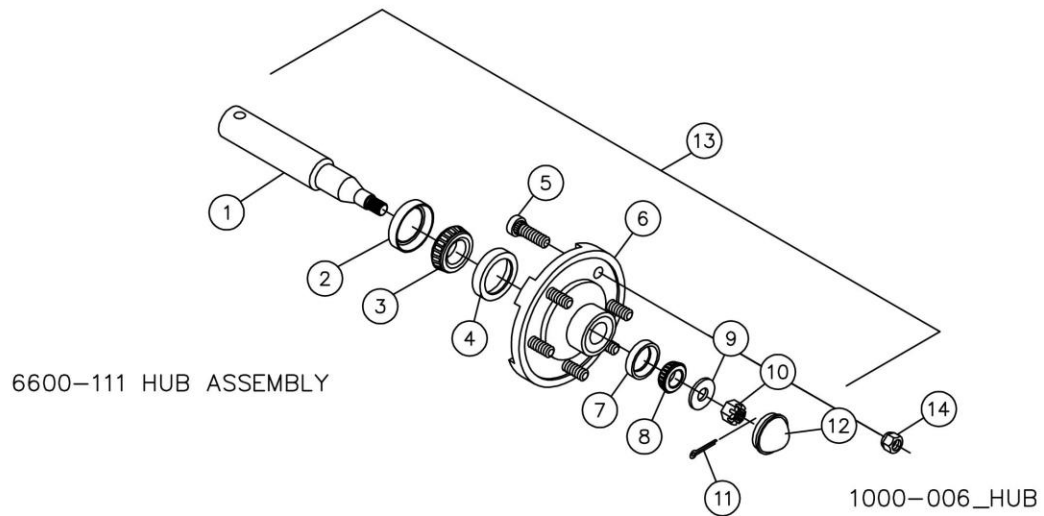

DET	QTY	PART NO.	DESCRIPTION
1	1	6600-336	SPINDLE
2	1	2570-191	SEAL (CR 17617)
3	1	2550-028	CONE LM29749
4	1	2550-030	CUP LM29710
5	6	2570-190	STUD BOLT 1/2-20
6	1	2570-189	HUB W/CUPS-STUDS
7	1	2550-029	CUP LM67010
8	1	2550-027	CONE LM67048
9	1	2526-501	3/4" FLATWASHER
10	1	2520-503	3/4"-16 SLOTTED HEX NUT
11	1	2531-106	3/16" X 1-3/4" COTTER PIN
12	1	2570-192	HUB CAP
13	1	6600-111	HUB ASSEMBLY 6 BOLT 6" B.C.
14	6	2520-360	1/2"-20 HEX NUT

Our name Is getting known

Just a few years ago, Yetter products were sold primarily to the Midwest only. Then we embarked on a program of expansion and moved into the East, the South, the West and now north into Canada. We're even getting orders from as far away as Australia and Africa.

So, when you buy Yetter products . . .you're buying a name that's recognized. A name that's known and respected. A name that's become a part of American agriculture and has become synonymous with quality and satisfaction in the field of conservation tillage.

Thank you.

YETTER MANUFACTURING CO.
Colchester, IL 62326-0358 • 309/776-4111
Toll Free 800/447-5777
Fax 309/776-3222
Website: WWW.YETTERCO.COM
E-MAIL: INFO@YETTERCO.COM

2565-787-REV A •09-2020